



AIMCO*
INTERNATIONAL GROUP

Strut Channels & Fittings



What we aim for:

Aimco International Group Corp.'s mission is to provide our customers with the highest quality products for the best value. Combining superior quality products with our world-class service, Aimco International has had unparalleled success in becoming a leading distributor of Strut Channels & Fittings, Pipe Hangers & Supports, Electrical & OEM Products, and Rigging & Tie-Down Hardware in the North American market.

As a manufacturer, we understand the importance of economy of scale and competitive advantage, thus our partnership with international manufacturers as well as domestic manufacturers provide our customers access to the most comprehensive line of products available in the industry. In fact, some of our overseas partners are the same factories providing the same products to some of the largest national manufacturers in North America.

Located in Toronto Canada, Aimco International is a privately owned Canadian company, our state-of-the-art facility contains an extensive inventory which helps guarantee customer satisfaction. By having a large and ready-to-ship inventory system, we strive to process and ship out orders on the same day or next day.

Our value is to adhere to the highest industry standards. Our management team has over a century of combined experience in the industry, supported by a team of engineers to help design specific products if a unique application arises. Aimco International's sales professionals know their business, understand their customers' needs, and make those needs their top priority. We meet customers' challenges with resourceful, innovative answers and unequalled commitment to insure customer success.

Aimco International Group Corp. uses its extensive years of manufacturing experience and partnership with qualified suppliers throughout the world to provide top quality products at competitive prices. Our goal is to continue to provide top quality products and maximize profits for our valued customers.

Aimco International - Aiming to Build a Better Future

STRUT CHANNELS AND FITTINGS

Aimco International Group Corp.

Metal Framing System Specifications and Guidelines

The specifications in this catalogue complies with the engineering principles and standards from the American Society for Testing and Materials (ASTM), National Fire Protection Association (NFPA), National Electrical Code (NEC) and other pertinent documents. The specifications are intended as a guide only, and it is the design engineer's responsibility to use it in conjunction with the information found in this catalogue to determine the best product or products for the user's application.

GENERAL GUIDELINES

I. PREPARATION

A. SCOPE OF WORK

- a) Prepare strut channels, associated fittings, related accessories and hardware.
- b) Provide all labour, supervision, engineering, and fabrication required for installation of the strut system in accordance with the contract drawings and as specified herein.

B. REFERENCES

- a) ASTM A108 - Specification for Steel Bars, Carbon, Cold-Finished, Structural Quality.
- b) ASTM A1011 - Specification for Steel, Sheet and Strip, Carbon, Hot-Rolled, Structural Quality.
- c) ASTM A1018 - Specification for Heavy-Thickness Coils, Steel, Sheet and Strip, Carbon, Hot-Rolled, Structural Quality.
- d) ASTM A123 - Specification for Hot-Dip Galvanized coatings on products fabricated from Rolled, Pressed, Forged Steel Shapes, Plates, Bars and Strips.
- e) ASTM B633 - Specification for Zinc Electro-Galvanized on Iron and Steel.
- f) ASTM A653 - Specification for Pre-Galvanized on Steel Sheet, Structural Quality.
- g) ASTM B117 - Specification for Epoxy Coating on Iron and Steel.

C. QUALITY ASSURANCE

- a) Manufacturers regularly engaged in the manufacture of channels, fittings, and accessories, whose products have been in satisfactory use in similar service for not less than 5 years.
- b) Manufacturers must provide information on the manufacturing standards for the products supplied.
- c) Installer should be a professional and experienced installer with not less than 5 years experience in the installation of strut systems of this size and conformation.

d) Work shall meet the requirements of the following standards: Federal, Provincial, State, Local Codes.

D. SUBMITTALS

a) Submit structural calculations for approval by the project engineer. Calculations include but are not limited to: description of design criteria, stress analysis, deflection analysis.

b) Submit manufacturers' specification sheets on the channels, fittings, and accessories including: materials, types, finishes, gauge thickness, hole patterns, and any other information necessary to completely install the metal framing system.

E. DELIVERY, STORAGE AND HANDLING

a) Deliver channels, fittings, and accessories carefully to avoid breakage, denting, and scoring finishes. Do not install damaged equipment.

b) Store channels, fittings, accessories and other components in original cartons and in clean dry space. All components shall be protected from weather and construction traffic, preferably by a shelter or other appropriate covering.

II. PRODUCTS

Material specifications for each strut channel type are as follows:

a) Pre-Galvanized Steel: strut channels shall be made from structural quality steel meeting the minimum mechanical properties of ASTM A1011 33,000 PSI minimum yield.

b) Hot-Dip Galvanized Steel: strut channel shall be made from structural quality steel meeting the minimum mechanical properties of ASTM A1011 33,000 PSI minimum yield.

c) Stainless Steel: strut channel shall be made from type 304 or type 316 stainless steel conforming to ASTM A240.

d) Aluminum Alloy: strut channels shall be made of extruded aluminum alloy 6063-T5.

Material specifications for each fitting and accessory type are as follows:

a) General Fittings: fittings shall be made from steel conforming to one of the following ASTM specifications: A1011, A1018, A108, A36, A240

b) Strut Pipe Clamps: strut pipe clamps shall be made from steel conforming to one of the following ASTM specifications: A1011, A1018, A108, A240

c) Spring Nuts: spring nuts shall be made from steel conforming to one of the following ASTM specifications: A108, A576, A240

d) Beam Clamps: beam clamps shall be made from steel conforming to one of the following ASTM specifications: A1011, A1018, A108, A36, A240

e) Electrical and Raceway Fittings: electrical and raceway fittings shall be made from steel conforming to one of the following ASTM specifications: A1011, A1018, A108, A240

Specifications for each type of finish are as follows:

- a) Pre-Galvanized Finish: channels shall be galvanized in accordance with ASTM A653 specifications.
- b) Hot-Dip Galvanized Finish: channels, fittings, and accessories shall be galvanized in accordance with one of the following ASTM specifications: A123, A153
- c) Zinc Electro-Galvanized Finish: fittings and accessories shall be galvanized in accordance with ASTM B633 specifications.
- d) Epoxy and Powder Coating Finish: channels, fittings, and accessories shall be coated in accordance with one of the following ASTM specifications: B117, D3451
- e) Stainless Steel: channels, fittings, and accessories shall be made in type 304 or type 316 stainless steel in accordance with ASTM A240 specifications.

III. EXECUTION

A. EXAMINATION

- a) The installer shall inspect the work area carefully prior to installation.
- b) If work area conditions are unsatisfactory, installation shall not proceed until satisfactory corrections are completed.

B. INSTALLATION

- a) Install metal framing system in accordance with recognized industry practices and equipment manufacturers' recommendations.
- b) Set metal framing components into final position true to line, level and plumb, in accordance with shop drawings.
- c) Anchor fittings and accessories firmly in place, and tighten all connections to their recommended torques.

C. CLEANUP

- a) Upon completion of this section of work, remove all protective wraps and debris.
- b) Repair any damage due to installation of this section of work.

D. PROTECTION

- a) During installation, it shall be the responsibility of the installer to protect this scope of work from damage.
- b) Upon completion of this scope of work, it shall become the responsibility of the general contractor to protect this work from damage during the remainder of construction on the project and until substantial completion.

FUNDAMENTALS OF DESIGN

BEAMS

Beams are members which are subjected to loads at right angles (perpendicular) to their length. Most commonly, beams are horizontal and are therefore subjected to vertical loads usually related to gravity, i.e.) a shelf, platform or support for pipe and conduit. Loads cause beams to bend, which is called deflection.

The ultimate consideration when designing a beam structure is whether or not it is strong enough. In other words, will it hold the anticipated load and provide a safety factor for unanticipated loads or other variations in conditions. A beam's ability to support a load is determined by its allowable bending moment and resulting amount of deflection. This load carrying ability is dependent on a number of factors: the amount of load, the type of load, the manner in which the beam is supported and the stiffness of the beam (a function of the beam's shape and the material from which it is made).

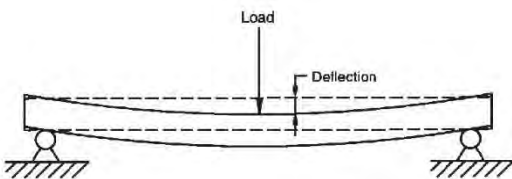
DEFLECTION

All beams will deflect or "sag" when a load is applied. The magnitude of the deflection is dependent on the following factors:

- a) The amount of load plus the weight of the beam itself.
- b) The manner in which the load is distributed.
- c) The method by which the beam is supported.
- d) The cross sectional shape of the beam.
- e) The material from which the beam is made.

The stiffness of the beam derived from its cross sectional shape is defined by its "Moment of Inertia" or "I". The greater the "I" value of a beam, the greater its stiffness and the smaller its deflection. "I" values are given for both major axis (X-X and Y-Y). Increasing the height of the strut channel (Y-Y axis) is a straightforward way to increase its stiffness and lower its deflection.

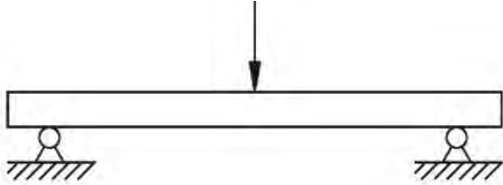
The stiffness of a beam derived from its material composition is defined by its "Modulus of Elasticity" or "E". The greater the "E" value of the beam's material, the stiffer it is, and the smaller the deflection. A material's elasticity does not necessarily relate to its strength but rather its deflection under a given load.



TYPES OF BEAM LOADING

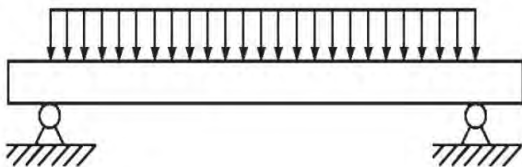
a) Point Load

A point load is concentrated at a single point along the beam's span (in reality, the load is concentrated over a very small length of the beam).



b) Uniform Load

A uniform load is spread evenly over the length of the beam from support to support.

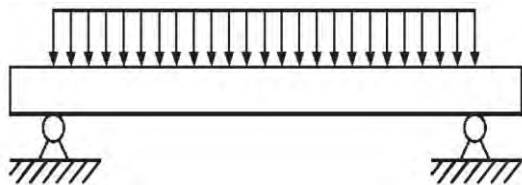


TYPES OF BEAM SUPPORT CONDITIONS

Strut channels are often installed to serve either as beams or columns in structural applications. A brief discussion of these types of structural elements and their safe design follows. Structural members installed in a horizontal attitude and subject to vertical and/or horizontal loads are known as beams. The method by which a beam is mounted affects the load-carrying capability of the beam. Common mounting methods are as follows:

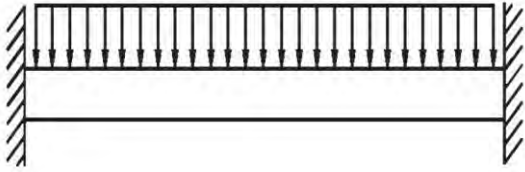
a) Simple Beam

A simple beam is supported at both ends by non-fixed connections which prevent vertical movement at the support point, but allow the beam to rotate or flex into a normal deflected shape. The majority of bolted metal framing connections closely approximate these conditions. The loading data presented in this catalogue is based on simple beam analysis unless otherwise noted.



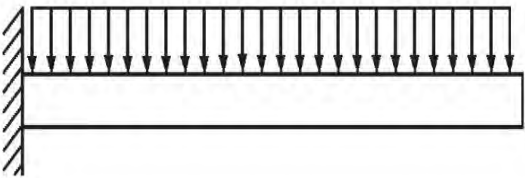
b) Fixed-End Beam

A fixed-end beam has rigid connections at each end that restrict the rotation of the beam and resist its deflection. The increased stiffness provided by this resistance to rotation provides a greater load capacity than that of an equivalent simple beam. A fixed-end beam would result when a channel span is welded to rigid upright supports.



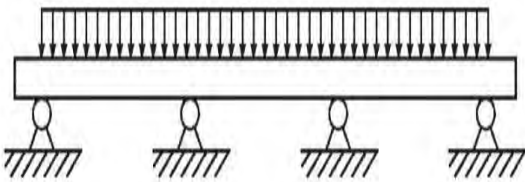
c) Cantilever Beam

A cantilever beam is supported by a fixed, rigid connection at one end and is totally unsupported at the opposite end. Shelf brackets and many of the strut brackets shown in this catalogue are examples of cantilever beams.



d) Continuous Beam

A continuous beam rests on more than two supports. The outside spans of a continuous beam will act like simple beams, while the interior spans will behave in a manner similar to fixed-end beams.



SAFETY FACTOR, STRESS AND BENDING MOMENT

Safety Factor is the ratio of ultimate load to the actual working load. The most important design consideration is the determination of adequate load bearing capacity. The beam must support its own weight, plus the weight of anticipated loads, and in addition, have enough capacity to safely handle unanticipated loads and variations in other relevant conditions. This "safety factor" is usually established by various design codes and standards. One method of measuring a beam's capacity is the allowable stress method whereby the beam's maximum allowable stress is determined in Pounds per Square Inch (PSI).

The maximum allowable uniform loads (and corresponding deflections) presented in this catalogue for strut channel beam loads are based on a simple beam configuration utilizing an allowable stress of 25,000 PSI. This maximum allowable stress provides a theoretical safety factor of 1.68 which is derived from carbon steel's minimum yield strength of 33,000 PSI, which is increased to 42,000 PSI as a result of the steel being cold-worked in the rolling process. In addition, the data given in this catalogue under maximum allowable uniform loads is consistent with the current American Iron and Steel Institute (AISI) "Specification for the Design of Cold-Formed Steel Structural Members".

As mentioned above, all beams will deflect or sag under load. It is worth noting that noticeable sagging is not an indication of an incorrectly designed beam installation. There may be situations however where it is desirable to address the visual appearance of an installation by minimizing deflection. In most applications, this “acceptable deflection” amount is typically given as a fraction of the span. 1/240 span deflection is typically the limit where the amount of deflection appears negligible. For example, a beam span of 240” would be allowed 1” (240/240) of deflection at the mid-point. A 120” span would only be allowed 1/2” (120/240) of deflection. The maximum load for the channel must be limited in order to remain under these deflection requirements.

BOLT TORQUE

Recommended bolt torque values are provided below. These torque values are suggested as a guideline to assist in arriving at the proper bolt tension. It should be kept in mind that the relationship between wrench torque and bolt tension is not always consistent. Factors affecting this relationship include metal finish and the presence or lack of a lubricant. Lubricated threads will increase the bolt tension for a given amount of torque applied, and could potentially result in over torqueing. The values shown here assume a properly calibrated torque wrench, and clean non-lubricated bolt, nut, washer, and fitting.

Bolt Size	1/4"-20	5/16"-18	3/8"-16	1/2"-13	5/8"-11	3/4"-10
Torque (ft.-lbs.)	6	11	19	50	100	125

COLUMNS

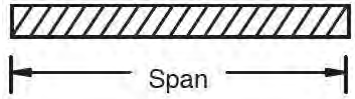
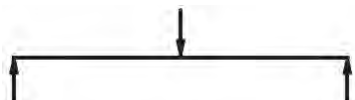

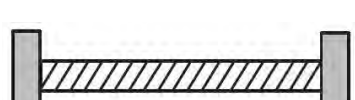
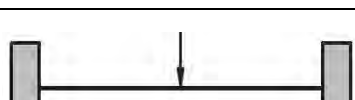



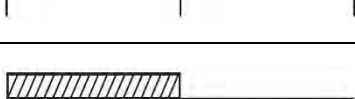


Columns are structural members which carry loads in compression. One common example of a channel column is the vertical members of a storage rack. While most often vertical, any structural member that is loaded in compression, such as a diagonal brace, is considered a column.

In theory, a column will carry a load equal to its cross sectional area multiplied by the ultimate compressive stress of the material of which the column is made. In reality, there are many factors affecting the load capacity of a column such as: the tendency to buckle or twist laterally (torsional-flexural buckling), the type of connection at the top or bottom, the eccentricity of the load application, and material imperfections. It is recommended that the engineer performs a detailed study of the many variable conditions before the selection process begins.

BEAM LOAD AND DEFLECTION CONVERSION FACTORS

The allowable beam loads listed for various spans of each channel assume that the beam is a simply supported, single-span beam. Although this is the most common condition, it is not always true. For other support conditions, multiply the listed allowable load by the factors in this table to obtain the proper load for the given mounting type.

GENERAL SPECIFICATIONS AND GUIDELINES

Load and Support Conditions	Diagram	Load Factor	Deflection Factor
1) Simple Beam: Uniform Load		1.00	1.00
2) Simple Beam: Concentrated Load at Mid-Span		0.50	0.80
3) Simple Beam: Two Equal Concentrated Load at 1/4 Points		1.00	1.10
4) Fixed-End Beam: Uniform Load		1.50	0.30
5) Fixed-End Beam: Concentrated Load at Mid-Span		1.00	0.40
6) Cantilever Beam: Uniform Load		0.25	2.40
7) Cantilever Beam: Concentrated Load at End		0.12	3.20
8) Continuous Beam: Two Equal Spans, Uniform Load Both Spans		1.00	0.42
9) Continuous Beam: Two Equal Spans, Uniform Load On One Span		1.30	0.92
10) Continuous Beam: Two Equal Spans, Concentrated Load at Mid-Span of Each		0.67	0.48
11) Continuous Beam: Two Equal Spans, Concentrated Load at Mid-Span of One		0.62	0.71

CORROSION

All metal surfaces are affected by corrosion. Depending on the physical properties of the metal and the environment to which it is exposed, chemical or electromechanical corrosion may occur. Common forms of corrosion are as follows:

ATMOSPHERIC CORROSION

Atmospheric corrosion occurs when metal is exposed to airborne liquids, solids or gases. Some sources of atmospheric corrosion are moisture, salt, dirt and sulphuric acid. This form of corrosion is typically more severe outdoors, especially near marine environments.

CHEMICAL CORROSION

Chemical corrosion takes place when metal comes in direct contact with a corrosive solution. Some factors which affect the severity of chemical corrosion include: chemical concentration level, duration of contact, frequency of washing, and operating temperature.

STORAGE CORROSION

Wet storage stain (white rust) is caused by the entrapment of moisture between surfaces of closely packed and poorly ventilated material for an extended period. Wet storage stain is usually superficial, having no affect on the properties of the metal.

Light staining normally disappears with weathering. Medium to heavy buildup should be removed in order to allow the formation of normal protective film. Proper handling and storage will help to assure stain-free material. If a product arrives wet, it should be unpacked and dried before storage. Dry material should be stored in a well ventilated "low moisture" environment to avoid condensation formation. Outdoor storage is undesirable, and should be avoided whenever possible.

GALVANIC CORROSION

Galvanic corrosion occurs when two or more dissimilar metals are in contact in the presence of an electrolyte (i.e. moisture). The anodic material will be the one to corrode. Anodic or cathodic characteristics of two dissimilar metals will depend on the type of each material. For example: If zinc and steel are in contact, the zinc acts as the anode and will corrode, the steel acts as the cathode, and will be protected. If steel and copper are in contact, the steel is now the anode and will corrode. The rate at which galvanic corrosion occurs depends on several factors:

- a) The amount and concentration of electrolyte present - an indoor, dry environment will have little or no galvanic corrosion compared to a wet atmosphere.
- b) The relative size of the materials – a small amount of anodic material in contact with a large cathodic material will result in greater corrosion. Likewise, a large anode in contact with a small cathode will decrease the rate of attack.

FINISHES

PRE-GALVANIZED (ASTM A653)

This type of finishing is suitable for moderate exposure in dry or mildly corrosive atmospheres but not generally recommended for use outdoors in industrial environments. Also known as “mill galvanized”, pre-galvanized finishing is produced by rolling the steel coils or sheets through molten zinc, at the steel mill, the material is then cut or slit to size. Coating thickness is 0.90 ounces per square foot of steel surface. Zinc near the uncoated edges or weld areas becomes a sacrificial anode which protects the bare areas.

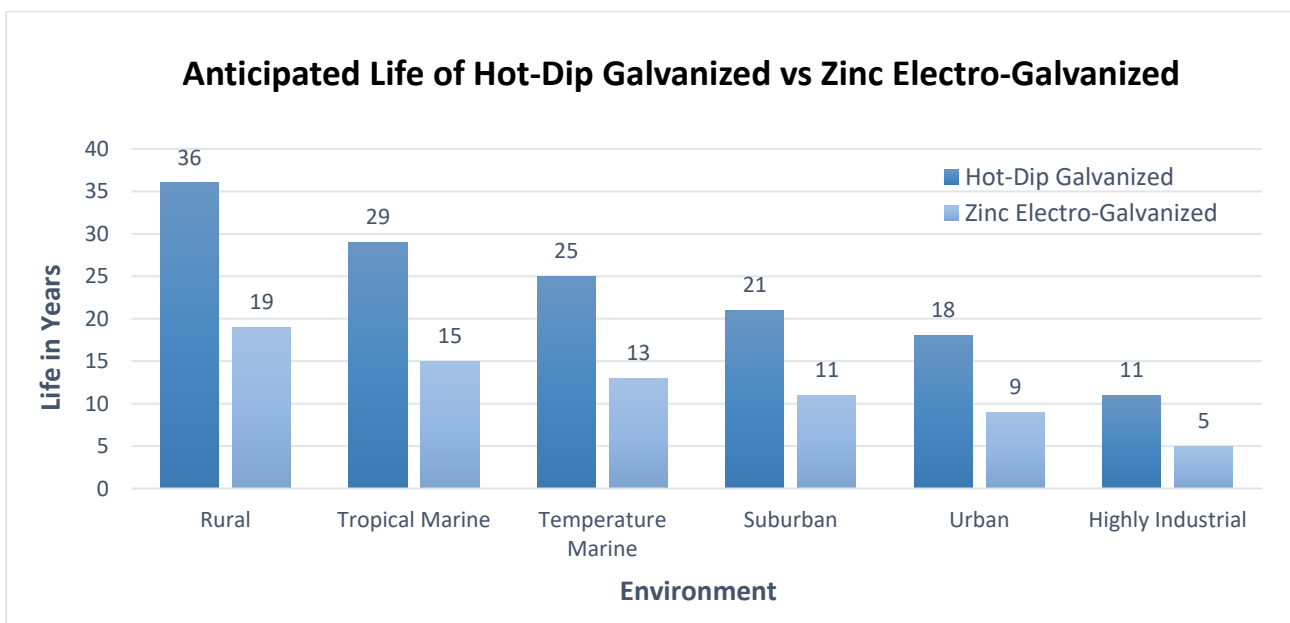
ZINC ELECTRO-GALVANIZED (ASTM B633)

This type of finishing (also known as Zinc Plated) is recommended for use indoors in relatively dry areas. The steel is submersed in a bath of zinc salts, through the process of electrolysis, a coating of pure zinc adheres to the steel with a molecular bond. A maximum of 0.5 mils of zinc can be applied using this method.

HOT-DIP GALVANIZED (ASTM A123)

This type of finishing is recommended for prolonged indoor and outdoor exposure, and will usually protect steel for 20 years or more in most atmospheric environments. Hot-Dip Galvanized (HDG) strut products are fabricated from steel and then completely immersed in a bath of molten zinc. A metallic bond occurs resulting in a zinc coating that completely coats all surfaces, including edges and welds, thus protects the steel substrate from direct contact with the environment.

One key advantage of the HDG finishing is the coating thickness. Strut products that are hot-dip galvanized after fabrication have an average thickness of 2.6 mils per square foot on each side of steel surface. The coating thickness is controlled by the amount of time each part is immersed in the molten zinc bath as well as the speed at which it is removed. The term “double dipping” refers to parts too large to fit into the galvanizing kettle, therefore must be dipped one end at a time, it does not refer to extra coating thickness.



EPOXY COATING (ASTM B117)

This type of finishing provides a superior level of corrosion protection compared to the traditional copper plating finish. It also insulates against dissimilar metal contact, thus preventing electrolysis. During the coating process, the parts are zinc plated to a thickness of 0.0002 inches, the copper or black color epoxy powder is applied by an electrostatic method, then the coated parts are baked at 82°C for 20 minutes.

COPPER PLATING

This coating is designed for copper tubing installations. The coating is intended to identify the product size only. This finish is not intended for corrosion resistance.

POWDER COATING (ASTM D3451)

This is a polyester powder coating that utilizes powder material, it is applied by means of electrostatic spray at ambient temperature.

NOTE

Weights given for all materials are approximate shipping weights. All dimensions are subject to commercial tolerance. All dimensions are in inches unless otherwise noted.

We reserve the right to make specification changes without prior notice.

While every effort has been made to assure the accuracy of the information contained in this catalogue at the time of publication, we cannot accept responsibility for inaccuracies resulting from undetected errors or omissions.

The blue color used on the components illustrated in this catalogue is for graphic enhancement only, and does not represent actual product color.

Table of Contents

PICTORIAL INDEX.....	i – vii
ROD STIFFENERS.....	1.1
Seismic Hanger Rod Stiffener	1.1
Rod Stiffener.....	1.1
CUSHION CLAMP & STRUT CLAMPS.....	2.1 – 2.7
Cushion Clamp.....	2.1
EMT Strut Pipe Clamp.....	2.2
RIGID Strut Pipe Clamp.....	2.2
Copper Epoxy Strut Pipe Clamp.....	2.3
O.D. Strut Pipe Clamp.....	2.4-2.5
Single Piece Strut Clamp.....	2.6
Cable Clamp.....	2.7
TROLLEYS	3.1 – 3.3
Two Wheel Plate Trolley.....	3.1
Four Wheel Plate Trolley	3.1
Four Wheel U Body Trolley.....	3.1
Four Wheel U Body Trolley with Eye Bolt	3.2
Two Wheel U Body Trolley	3.2
Trolley Support Splice.....	3.2
Trolley Support Splice Heavy Duty	3.3
COMBO NUT WASHER & SPRING NUTS	4.1 – 4.5
Combo Nut Washer	4.1
Spring Nut Regular Spring	4.2
Spring Nut No Spring	4.3
Spring Nut Short Spring	4.4
Spring Nut Long Spring	4.5
GENERAL FITTINGS	5.1 – 5.20
Square Washers	5.1
Square Washer	5.1
Square Washer No Twist	5.1
Steel Washer Plate	5.1
Splicing Connections.....	5.2-5.4
Two Hole Splice Plate	5.2

TABLE OF CONTENTS

Three Hole Splice Plate	5.2
Four Hole Splice Plate	5.2
Two Hole Splice	5.3
Three Hole Splice	5.3
Four Hole Splice	5.3
U Shape Strut Splice (with nuts)	5.4
Corner Connections	5.4-5.9
Three Hole Flat Plate	5.4
Four Hole Flat Plate	5.5
Tee Pate	5.5
Three Hole Corner Plate	5.5
Four Hole Corner Plate	5.6
Five Hole Corner Plate	5.6
Three Hole Tee Plate	5.6
Four Hole Tee Plate	5.7
Five Hole Tee Plate	5.7
Two Hole 90° Fitting	5.7
Two Hole 90° Fitting No Twist	5.8
Three Hole 90° Fitting	5.8
Left Four Hole Angle	5.8
Right Four Hole Angle	5.9
Crossing Connections	5.9-5.16
Two Hole Angle	5.9
Three Hole Angle	5.10
Three Hole Connector	5.10
Four Hole Angle	5.10
Z Shape Angle	5.11
U Shape Bracket	5.11
Four Hole Angle Fitting	5.11
Five Hole Angle Fitting	5.12
Five Hole Cross Plate	5.12
Universal Shelf Bracket	5.12
Five Hole Shelf Bracket	5.13
Five Hole Wing Fitting	5.13
Six Hole Wing Fitting	5.13

Eight Hole Wing Fitting 5.14

Nine Hole Wing Fitting 5.14

Ten Hole Wing Fitting 5.14

Twelve Hole Wing Fitting..... 5.15

Four Hole Corner Fitting 5.15

Six Hole Corner Fitting 5.15

Eight Hole Corner Fitting 5.16

Two Hole Corner Fitting 5.16

Four Hole Corner 5.16

Angle Connections..... 5.17-5.18

Two Hole Open Angle 5.17

Four Hole Open Angle 5.17

Two Hole Closed Angle 5.17

Four Hole Closed Angle 5.18

Three Hole Adjustable Plate 5.18

Post Bases 5.19-5.20

Single Post Base 5.19

Offset Single Post Base 5.19

Single Post Base Short 5.19

Double Post Base..... 5.20

Single Post Base Open 5.20

Single Post Base Narrow 5.20

Offset Connections 5.21

Wall Ladder Bracket 5.21

Clevis Connector 5.21

Offset Connector 5.21

BEAM CLAMPS 6.1 – 6.8

Window Beam Clamp 6.1

Window Beam Clamp Deep..... 6.1

U-Bolt Beam Clamp 6.1

U-Bolt Beam Clamp Deep 6.2

Flange Strut Beam Clamp 6.2

Z Shape Beam Clamp 6.2

Strut Beam Clamp 1” Opening 6.3

Strut Beam Clamp 1 1/2” Opening 6.3

TABLE OF CONTENTS

Strut Beam Clamp 2 1/8" Opening	6.3
Strut Beam Clamp 2 1/2" Opening	6.4
Strut Beam Clamp 7/8" Opening	6.4
Strut Beam Clamp 1 21/32" Opening	6.4
Strut Clevis Hanger	6.5
Safety Strap	6.5
Column Insert	6.5
Column Insert Square	6.6
J-Hook Beam Clamp.....	6.6
J-Hook Beam Clamp Double	6.7
J-Hook Beam Clamp Heavy Duty	6.7
J-Hook Beam Clamp Light Duty	6.8
BRACKETS.....	7.1 – 7.4
Bracket for Single Channel	7.1
Bracket for Double Channel	7.1
Single Channel Support Bracket	7.2
Double Channel Support Bracket	7.2
Cantilever Strut Bracket	7.3
Shelf Bracket.....	7.3
Knee Brace.....	7.4
ELECTRICAL & RACEWAY FITTINGS	8.1 – 8.3
Safety End Cap PVC	8.1
Safety End Cap Metal	8.1
End Cap with Knock-Out.....	8.1
Fixture Stud Nut	8.2
Wiring Stud Nut	8.2
Inside Splice	8.2
Channel Hanger	8.3
Plastic Closure Strip	8.3
STRUT CHANNELS.....	9.1 – 9.2
Single Channel (Solid)	9.1
Single Channel (Slots)	9.1
Single Channel (Holes).....	9.1
Double Channel Back to Back.....	9.2
ADJUSTABLE HINGES & BRACES.....	10.1 – 10.2

Adjustable Hinge Two Hole10.1

Adjustable Hinge Three Hole.....10.1

Adjustable Hinge Four Hole.....10.1

Adjustable Brace.....10.2

Adjustable Brace Double10.2

PIPE ROLLERS & ACCESSORIES 11.1 – 11.2

 Pipe Block 11.1

 Pipe Roller..... 11.1

 Pipe Roller Connected 11.1

 Pipe Roller Double11.2

 Pipe Roller Triple 11.2

TECHNICAL DATA..... I – VIII

 Elements of Steel Strut Channels I

 Beam Load Data II-VI

 I Beam Data VII

 Electrical Metallic Tubing (EMT) Data VIII

 Steel Rigid Conduit Data VIII

 Aluminum Rigid Conduit Data IX

 Intermediate Rigid Conduit (IMC) Data IX

 National Electrical Code Data IX

 Schedule 40 Steel Pipe DataX

 Schedule 80 Steel Pipe DataXI

 AWWA Ductile Iron Pipe DataXII

 No-Hub Cast Iron Soil Pipe DataXII

 Copper Tubing (Type L) DataXIII

 Copper Tubing (Type K) Data.....XIII

 Recommended Hanger Spacing and Rod Size for Copper Tubing..... XIV

 Regular Schedule Glass Pipe Data XIV

 Heavy Schedule Glass Pipe Data..... XIV

 Schedule 40 PVC Plastic Pipe Data XV

 Schedule 80 PVC Plastic Pipe Data XV

 Spacing of Hangers for Schedule 40 PVC Plastic Pipe Data XVI


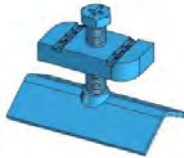
 Spacing of Hangers for Schedule 80 PVC Plastic Pipe Data XVI

 Rod Size as Determined by Steel Pipe Size for Fire Protection XVII

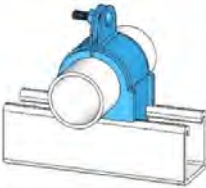





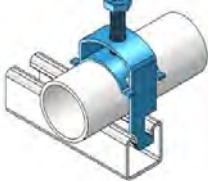
TABLE OF CONTENTS

Rod Size as Determined by Copper Tubing Size for Fire Protection.....	XVII
Hanger Rod Load Capacities – Hot Rolled Steel Rod	XVII
Conversion Factors for Units of Measurement	XVIII

ROD STIFFENERS

 <p>A-SC228 Seismic Hanger Rod Stiffener Page 1.1</p>	 <p>A-901 Rod Stiffener Page 1.1</p>
---	--

CUSHION CLAMP & STRUT CLAMPS

 <p>A-8500 Cushion Clamp Page 2.1</p>	 <p>A-910E EMT Strut Pipe Clamp Page 2.2</p>	 <p>A-910R Rigid Strut Pipe Clamp Page 2.2</p>	 <p>A-910C Copper Epoxy Strut Pipe Clamp Page 2.3</p>	 <p>A-9100D O.D. Strut Pipe Clamp Page 2.4-2.5</p>
 <p>A-CAD SCH Single Piece Strut Clamp Page 2.6</p>	 <p>A-081... Cable Clamp Page 2.7</p>			

TROLLEYS

 <p>A-2521 Two Wheel Plate Trolley Page 3.1</p>	 <p>A-2522 Four Wheel Plate Trolley Page 3.1</p>	 <p>A-2524 Four Wheel U Body Trolley Page 3.1</p>	 <p>A-2524EB Four Wheel U Body Trolley with Eye Bolt Page 3.2</p>	 <p>A-2525 Two Wheel U Body Trolley Page 3.2</p>
---	--	---	--	--

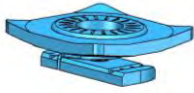


A-2528
Trolley Support
Splice
Page 3.2

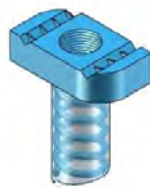


A-2529
Trolley Support
Splice Heavy Duty
Page 3.3

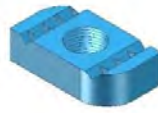
COMBO NUT WASHER & SPRING NUTS



A-NW528...
Combo Nut Washer
Page 4.1



A-900RG
Spring Nut Regular
Spring
Page 4.2



A-900NS
Spring Nut No
Spring
Page 4.3



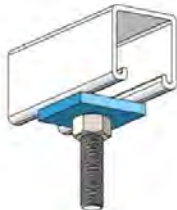
A-900SH
Spring Nut Short
Spring
Page 4.4



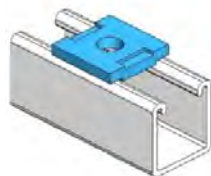
A-900LS
Spring Nut Long
Spring
Page 4.5

GENERAL FITTINGS

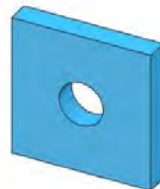
Square Washers



A-619...
Square Washer
Page 5.1



A-619NT...
Square Washer No
Twist
Page 5.1



A-2 x 2 9/16...
Steel Washer Plate
Page 5.1

Splicing Connections



A-601
Two Hole Splice
Plate
Page 5.2



A-602
Three Hole Splice
Plate
Page 5.2





A-723
Four Hole Splice
Plate
Page 5.2






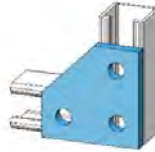


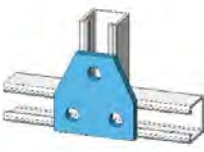





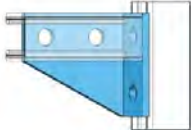
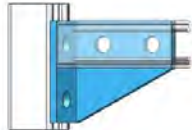
A-409U
Two Hole Splice
Page 5.3




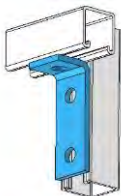
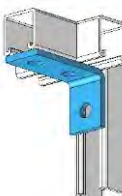
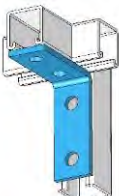
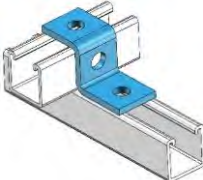
A-412U
Three Hole Splice
Page 5.3

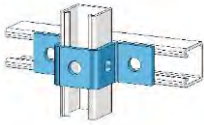
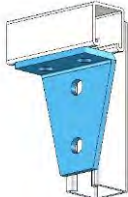

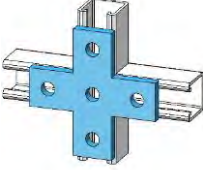
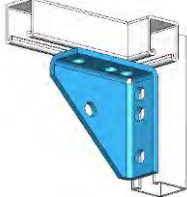

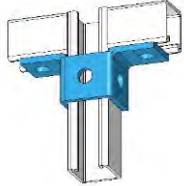
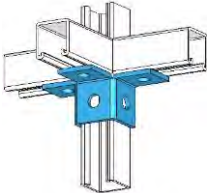
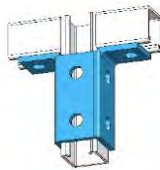
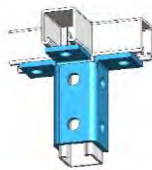
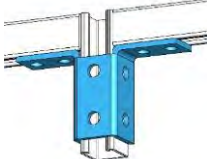
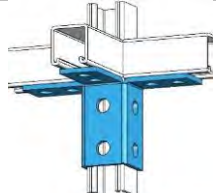
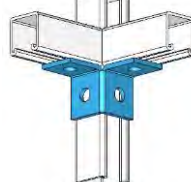
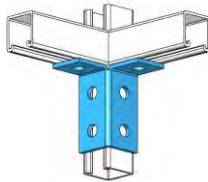
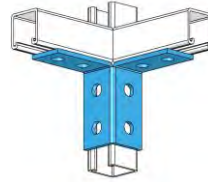
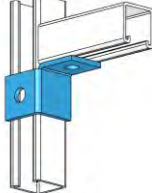
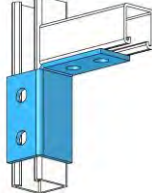
 <p>A-616 Four Hole Splice Page 5.3</p>	 <p>A-649 U Shape Strut Splice (with nuts) Page 5.4</p>
---	---

Corner Connections

 <p>A-718 Three Hole Flat Plate Page 5.4</p>	 <p>A-123P Four Hole Flat Plate Page 5.5</p>	 <p>A-714 Tee Plate Page 5.5</p>	 <p>A-744 Three Hole Corner Plate Page 5.5</p>	 <p>A-750 Four Hole Corner Plate Page 5.6</p>
 <p>A-751 Five Hole Corner Plate Page 5.6</p>	 <p>A-925 Three Hole Tee Plate Page 5.6</p>	 <p>A-747 Four Hole Tee Plate Page 5.7</p>	 <p>A-854 Five Hole Tee Plate Page 5.7</p>	 <p>A-603 Two Hole 90° Fitting Page 5.7</p>
 <p>A-207A Two Hole 90° Fitting No Twist Page 5.8</p>	 <p>A-210A Three Hole 90° Fitting Page 5.8</p>	 <p>A-742 Left Four Hole Angle Page 5.8</p>	 <p>A-743 Right Four Hole Angle Page 5.9</p>	

Crossing Connections

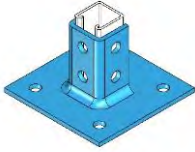
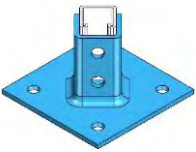

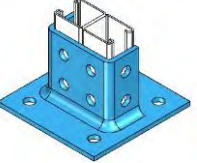
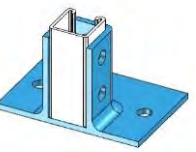
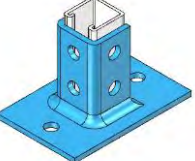
 <p>A-604 Two Hole Angle Page 5.9</p>	 <p>A-606 Three Hole Angle Page 5.10</p>	 <p>A-605 Three Hole Connector Page 5.10</p>	 <p>A-607 Four Hole Angle Page 5.10</p>	 <p>A-611... Z Shape Angle Page 5.11</p>
---	--	--	--	--

 <p>A-613... U Shape Bracket Page 5.11</p>	 <p>A-748 Four Hole Angle Fitting Page 5.11</p>	 <p>A-230A Five Hole Angle Fitting Page 5.12</p>	 <p>A-712 Five Hole Cross Plate Page 5.12</p>	 <p>A-608 Universal Shelf Bracket Page 5.12</p>
 <p>A-216A... Five Hole Shelf Bracket Page 5.13</p>	 <p>A-923 Five Hole Wing Fitting Page 5.13</p>	 <p>A-668 Six Hole Wing Fitting Page 5.13</p>	 <p>A-821 Eight Hole Wing Fitting Page 5.14</p>	 <p>A-670 Nine Hole Wing Fitting Page 5.14</p>
 <p>A-913 Ten Hole Wing Fitting Page 5.14</p>	 <p>A-669 Twelve Hole Wing Fitting Page 5.15</p>	 <p>A-665 Four Hole Corner Fitting Page 5.15</p>	 <p>A-666 Six Hole Corner Fitting Page 5.15</p>	 <p>A-667 Eight Hole Corner Fitting Page 5.16</p>
 <p>A-922 Two Hole Corner Fitting Page 5.16</p>	 <p>A-2128 Four Hole Corner Page 5.16</p>			

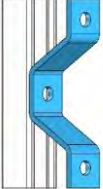
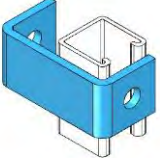
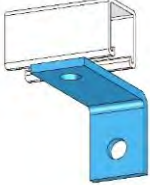
Angle Connections

 <p>A-633 Two Hole Open Angle Page 5.17</p>	 <p>A-781 Four Hole Open Angle Page 5.17</p>	 <p>A-624 Two Hole Closed Angle Page 5.17</p>	 <p>A-793 Four Hole Closed Angle Page 5.18</p>	 <p>A-117P Three Hole Adjustable Plate Page 5.18</p>
--	---	--	--	---

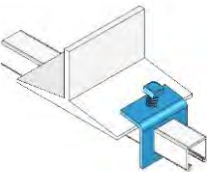
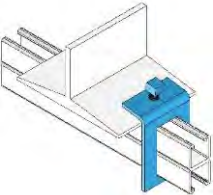
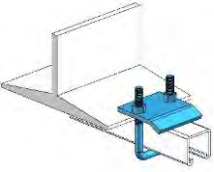
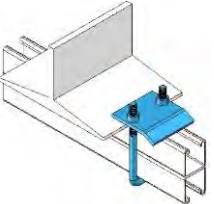
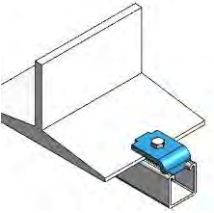
Post Bases

 <p>A-3033 Single Post Base Page 5.19</p>	 <p>A-30330 Offset Single Post Base Page 5.19</p>	 <p>A-503PB Single Post Base Short Page 5.19</p>	 <p>A-3064 Double Post Base Page 5.20</p>	 <p>A-508PB... Single Post Base Open Page 5.20</p>
 <p>A-509PB Single Post Base Narrow Page 5.20</p>				

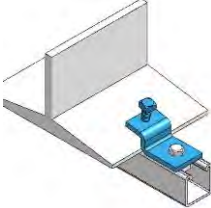
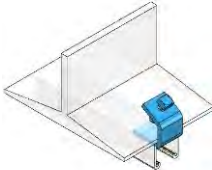
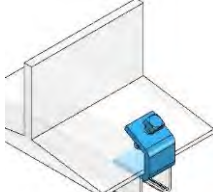
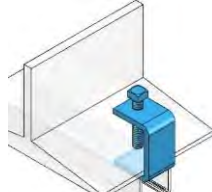
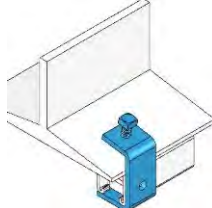

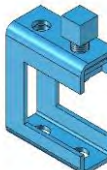

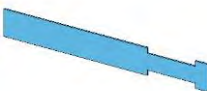
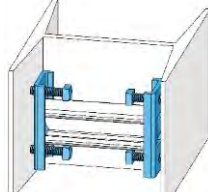
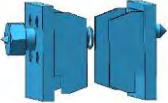
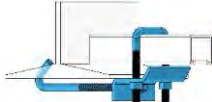

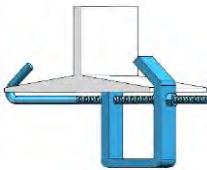
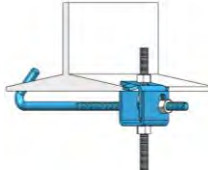
Offset Connections

 <p>A-1204... Wall Ladder Bracket Page 5.21</p>	 <p>A-402U... Clevis Connector Page 5.21</p>	 <p>A-208 Offset Connector Page 5.21</p>
---	--	--

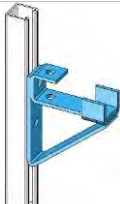
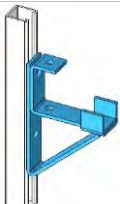
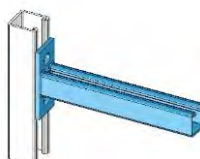
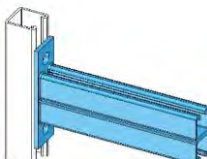

BEAM CLAMPS


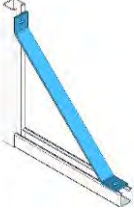
 <p>A-855 Window Beam Clamp Page 6.1</p>	 <p>A-855D Window Beam Clamp Deep Page 6.1</p>	 <p>A-2652 U-Bolt Beam Clamp Page 6.1</p>	 <p>A-2651 U-Bolt Beam Clamp Deep Page 6.2</p>	 <p>A-686 Flange Strut Beam Clamp Page 6.2</p>
--	--	---	---	--

PICTORIAL INDEX

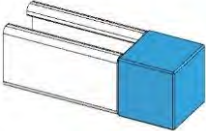
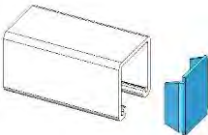
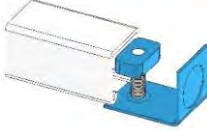



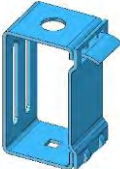

 <p>A-685 Z Shape Beam Clamp Page 6.2</p>	 <p>A-907A Strut Beam Clamp 1" Opening Page 6.3</p>	 <p>A-907B Strut Beam Clamp 1 1/2" Opening Page 6.3</p>	 <p>A-907C Strut Beam Clamp 2 1/8" Opening Page 6.3</p>	 <p>A-684 Strut Beam Clamp 2 1/2" Opening Page 6.4</p>
 <p>A-2622HD 7/8 Strut Beam Clamp 7/8" Opening Page 6.4</p>	 <p>A-2622HD 1 21/32 Strut Beam Clamp 1 21/32" Opening Page 6.4</p>	 <p>A-2623 Strut Clevis Hanger Page 6.5</p>	 <p>A-2622 Safety Strap Page 6.5</p>	 <p>A-954BC Column Insert Page 6.5</p>
 <p>A-CAD BC23 Column Insert Square Page 6.6</p>	 <p>A-948SBC J-Hook Beam Clamp Page 6.6</p>	 <p>A-949SBC J-Hook Beam Clamp Double Page 6.7</p>	 <p>A-997BC... J-Hook Beam Clamp Heavy Duty Page 6.7</p>	 <p>A-984... J-Hook Beam Clamp Light Duty Page 6.8</p>

BRACKETS

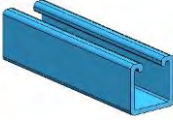
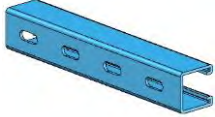
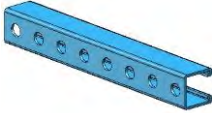
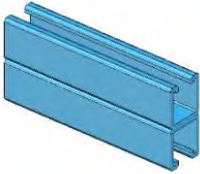
 <p>A-708 Bracket for Single Channel Page 7.1</p>	 <p>A-709 Bracket for Double Channel Page 7.1</p>	 <p>A-651 Single Channel Support Bracket Page 7.2</p>	 <p>A-809 Double Channel Support Bracket Page 7.2</p>	 <p>A-3282 Cantilever Strut Bracket Page 7.3</p>
---	---	---	--	--

 <p>A-690B Shelf Bracket Page 7.3</p>	 <p>A-926 Knee Brace Page 7.4</p>
--	--



ELECTRICAL & RACEWAY FITTINGS

 <p>A-655P Safety End Cap PVC Page 8.1</p>	 <p>A-655 Safety End Cap Metal Page 8.1</p>	 <p>A-2511 End Cap with Knock-Out Page 8.1</p>	 <p>A-2636 Fixture Stud Nut Page 8.2</p>	 <p>A-2625 Wiring Stud Nut Page 8.2</p>
 <p>A-643 Inside Splice Page 8.2</p>	 <p>A-2632 Channel Hanger Page 8.3</p>	 <p>A-707PL 10 Plastic Closure Strip Page 8.3</p>		


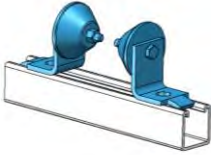
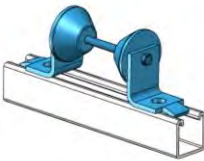

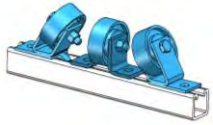
STRUT CHANNELS

 <p>A-20... Single Channel Page 9.1</p>	 <p>A-20SL... Single Channel with Slots Page 9.1</p>	 <p>A-20HS Single Channel with Holes Page 9.1</p>	 <p>A-20BB... Double Channel Back-to-Back Page 9.2</p>
--	---	--	--

ADJUSTABLE HINGES & BRACES

 <p>A-292A Adjustable Hinge Two Hole Page 10.1</p>	 <p>A-293A Adjustable Hinge Three Hole Page 10.1</p>	 <p>A-294A Adjustable Hinge Four Hole Page 10.1</p>	 <p>A-298A Adjustable Brace Page 10.2</p>	 <p>A-299A Adjustable Brace Double Page 10.2</p>
--	--	---	--	--

PIPE ROLLERS & ACCESSORIES

 <p>A-11PC Pipe Block Page 11.1</p>	 <p>A-1PR Pipe Roller for 1/2" - 4" Pipe Page 11.1</p>	 <p>A-2PR... Pipe Roller for 1" - 8" Pipe Page 11.1</p>	 <p>A-6PR Pipe Roller for 6" - 16" Pipe Page 11.2</p>	 <p>A-7PR Pipe Roller for 16" - 24" Pipe Page 11.2</p>
--	---	--	---	---

Section 1: Rod Stiffeners

FUNCTIONS AND FEATURES

Seismic Hanger Rod Stiffeners are designed to secure channel to hanger rod for vertical seismic bracing. In other words, they are used to prevent the buckling of the hanger rods under the compressive reaction loads during an earthquake. Buckling is very difficult to predict, and depends on many factors such as: hanger rod length, hanger rod size, the dead load carried by the hanger rod, the horizontal seismic forces applied to the pipe or duct, and the seismic restraint installation angle. Buckling occurs in long slender structural members under compressive load, and it occurs at loads far less than those required to yield the material in the structural member.

Rod stiffeners are required only on hanger and trapeze that have seismic bracing attached at or within 4" of the rod. A minimum of two rod stiffeners must be installed. Recommended torque is 8 ft.-lbs. or finger tight and one full turn with a wrench.

MATERIAL

Carbon Steel (ASTM A1011)

THREADS

Conforms to Unified Screw Thread(UNC) standard, ANSI B1.1, coarse series UNC Class 2

BOLT & SCREW

Conforms to SAE J429 GR 2 (exceeds ASTM A307). Proof Load 55KSI, Tensile Load 74 KSI

FINISH

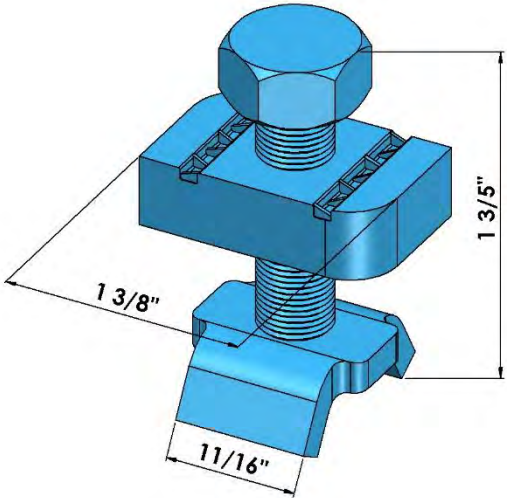
Zinc Electro-Galvanized (ASTM B633)

NOTE

Slight distortion of the channel may occur upon installation of rod stiffeners.

SEISMIC HANGER ROD STIFFENER

Part # | A-SC228

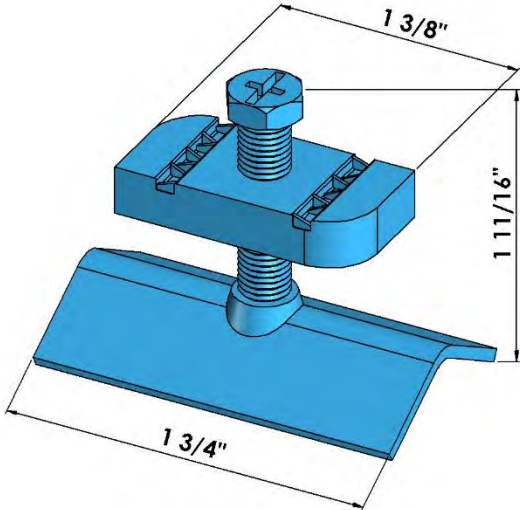


Specification Data	
Rod Size Range (in.)	3/8 through 5/8
Approx. Wt. (lbs.)	0.15

Rod Stiffener Requirements		
Rod Size (in.)	Max. Rod Length without Rod Stiffener (in.)	Max. Spacing between Rod Stiffeners (in.)
3/8	19	13
1/2	25	18
5/8	31	23
3/4	37	28
7/8	43	33
1	50	38
1 1/4	60	43

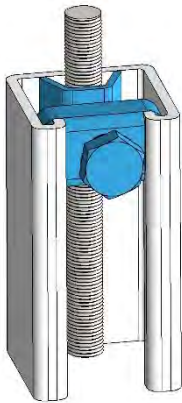
ROD STIFFENER

Part # | A-901



Specification Data	
Rod Size Range (in.)	3/8 through 5/8
Approx. Wt. (lbs.)	0.12

Rod Stiffener Requirements		
Rod Size (in.)	Max. Rod Length without Rod Stiffener (in.)	Max. Spacing between Rod Stiffeners (in.)
3/8	19	13
1/2	25	18
5/8	31	23
3/4	37	28
7/8	43	33
1	50	38
1 1/4	60	43



These specifications are for reference only. Aimco International Group Corp. reserves the right to make changes to the design without prior notice.

Section 2: Cushion Clamp & Strut Clamps

FUNCTIONS AND FEATURES

Cushion Clamps are ideal for multiple line runs, and they mount to standard 1 5/8" wide strut channels. They absorb shock and vibration, reduce unwanted noise and avoid galvanic corrosion, and eliminate metal to metal contact (non-conducting). They also allow fluid conductors to be added or removed from installations without disturbing adjacent lines, and permit various size lines to be mixed to suit installation.

The thermoplastic elastomer (TPE) cushion living range allows for quick installation and relocation of the cushion and pipe. The TPE has a working temperature range of -46°C to 135°C, and resists the effects of most oils, chemicals and industrial cleaners. The shoulder stud is securely fastened to one clamp half, and the "controlled squeeze" shoulder bolt helps to eliminate over-tightening and rotation while a nylon insert nut assures a positive lock. Moreover, retrofits can be added without disassembling present or existing system.

A-CAD SCH series Single Piece Strut Clamp fits to any standard 1 5/8" wide strut channel. They are one of the quickest and easiest methods of attaching EMT or rigid conduits to channel. They require only a screwdriver or nut driver for installation, which means there are no screws or bolts to drop during installation. To protect cables on the bearing surface of the channel or tray, all sizes of the Single Piece Strut Clamps are available with load distribution plate attached to the screw.

MATERIALS

Carbon Steel (ASTM A1011)

Thermoplastic Elastomer insulating liner (for Cushion Clamp only)

BOLT & SCREW

Conforms to ASTM A307

FINISHES

Zinc Electro-Galvanized (ASTM B633)

Epoxy Coating (ASTM B117)

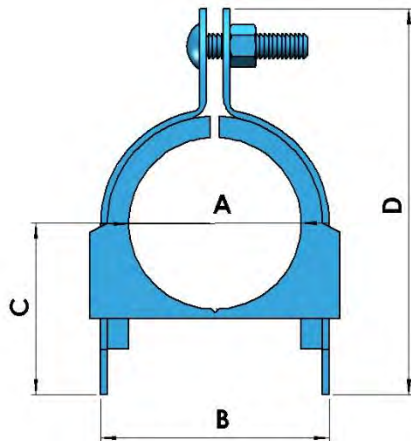
STAINLESS STEEL OPTIONS

All Cushion Clamps, EMT, Rigid, and O.D. Strut Clamps are available in 304 Stainless Steel or 316 Stainless Steel (ASTM A240)

NOTE

To help save installation time, hex head screw and nut are pre-assembled on each of the EMT, Rigid, and O.D. Strut Clamps.

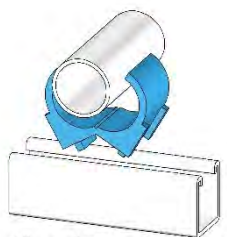
These specifications are for reference only. Aimco International Group Corp. reserves the right to make changes to the design without prior notice.



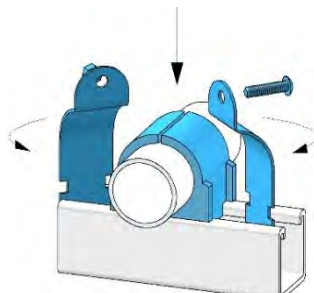
CUSHION CLAMP

Part #	Copper & Steel Tube O.D. (in.)	Copper Water Pipe Nom. (in.)	O.D. A (in.)	B (in.)	C (in.)	D (in.)	Approx. Wt. (lbs.)
A-8500 1/4	1/4	-	0.25	0.62	0.27	0.98	0.11
A-8500 3/8	3/8	1/4	0.37	0.82	0.33	1.13	0.12
A-8500 1/2	1/2	3/8	0.50	0.94	0.40	1.34	0.13
A-8500 5/8	5/8	1/2	0.62	1.06	0.46	1.54	0.14
A-8500 3/4	3/4	5/8	0.75	1.20	0.52	1.68	0.18
A-8500 7/8	7/8	3/4	0.87	1.31	0.58	1.82	0.19
A-8500 1	1	-	1.00	1.44	0.65	1.95	0.24
A-8500 1 1/8	1 1/8	1	1.12	1.57	0.70	2.08	0.25
A-8500 1 1/4	1 1/4	-	1.25	1.70	0.77	2.21	0.26
A-8500 1 3/8	1 3/8	1 1/4	1.37	1.82	0.83	2.34	0.31
A-8500 1 1/2	1 1/2	-	1.50	1.95	0.90	2.47	0.32
A-8500 1 5/8	1 5/8	1 1/2	1.62	2.07	0.96	2.60	0.38
A-8500 1 3/4	1 3/4	-	1.75	2.20	1.02	2.73	0.42
A-8500 1 7/8	1 7/8	-	1.90	2.32	1.09	2.86	0.45
A-8500 2	2	-	2.00	2.45	1.15	3.04	0.45
A-8500 2 1/8	2 1/8	2	2.12	2.57	1.27	3.23	0.51
A-8500 2 3/8	2 3/8	-	2.37	2.82	1.41	3.67	0.62
A-8500 2 1/2	2 1/2	-	2.50	2.94	1.46	3.79	0.62
A-8500 2 5/8	2 5/8	2 1/2	2.62	3.07	1.53	3.92	0.62
A-8500 3	3	-	3.00	3.57	1.78	4.42	0.68
A-8500 3 1/8	3 1/8	3	3.12	3.57	1.78	4.42	0.68
A-8500 4 1/8	4 1/8	4	4.12	4.57	2.34	5.54	0.90

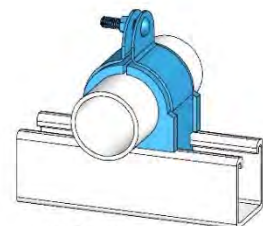
Cushion Clamp Installation:



Align pipe and cushion

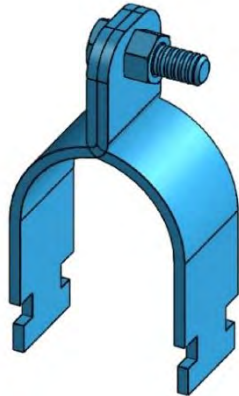


Insert clamp into strut



Tighten using nut

These specifications are for reference only. Aimco International Group Corp. reserves the right to make changes to the design without prior notice.



STRUT PIPE CLAMPS

EMT STRUT PIPE CLAMP (FOR ELECTRICAL METALLIC TUBING/THIN WALL CONDUIT)

Part #	Conduit Size (in.)	O.D. (in.)	Design Load (lbs.)	Safety Factor	Approx. Wt. (lbs.)
A-910E 3/8	3/8	0.577	400	5.0	0.10
A-910E 1/2	1/2	0.706	400	5.0	0.10
A-910E 3/4	3/4	0.922	400	5.0	0.11
A-910E 1	1	1.163	600	5.0	0.15
A-910E 1 1/4	1 1/4	1.510	600	5.0	0.17
A-910E 1 1/2	1 1/2	1.740	800	5.0	0.25
A-910E 2	2	2.197	800	5.0	0.31

Note: For EMT sizes greater than 2", use equivalent rigid strut pipe clamp. EMT conduits shall be supported at least every 10 ft and within 3 ft of each outlet box, junction box, or fitting.

RIGID STRUT PIPE CLAMP (FOR RIGID CONDUIT/HEAVY WALL CONDUIT)

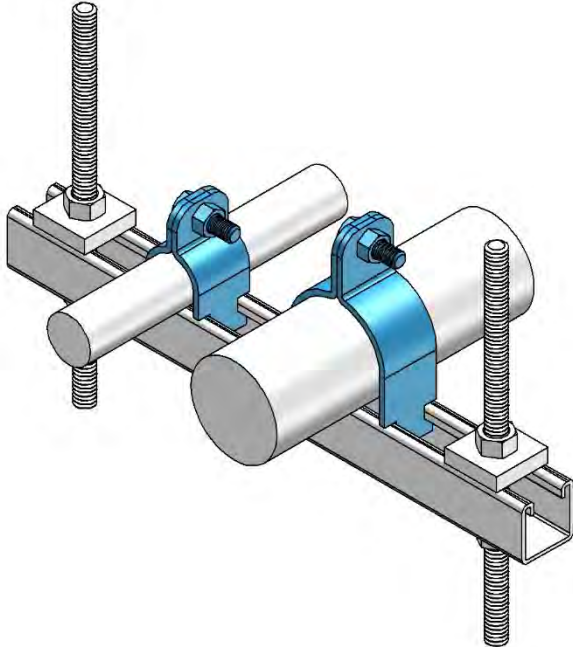
Part #	Conduit Size (in.)	O.D. (in.)	Design Load (lbs.)	Safety Factor	Approx. Wt. (lbs.)
A-910R 3/8	3/8	0.675	400	5.0	0.11
A-910R 1/2	1/2	0.840	400	5.0	0.11
A-910R 3/4	3/4	1.050	600	5.0	0.16
A-910R 1	1	1.315	600	5.0	0.18
A-910R 1 1/4	1 1/4	1.660	600	5.0	0.20
A-910R 1 1/2	1 1/2	1.900	800	5.0	0.28
A-910R 2	2	2.375	800	5.0	0.33
A-910R 2 1/2	2 1/2	2.875	800	5.0	0.37
A-910R 3	3	3.500	800	5.0	0.40
A-910R 3 1/2	3 1/2	4.000	1000	5.0	0.54
A-910R 4	4	4.500	1000	5.0	0.61
A-910R 5	5	5.563	1000	5.0	0.99
A-910R 6	6	6.625	1000	5.0	0.99
A-910R 8	8	8.625	1000	5.0	1.23
A-910R 10	10	10.750	1000	5.0	1.51
A-910R 12	12	12.750	1000	5.0	1.81

These specifications are for reference only. Aimco International Group Corp. reserves the right to make changes to the design without prior notice.

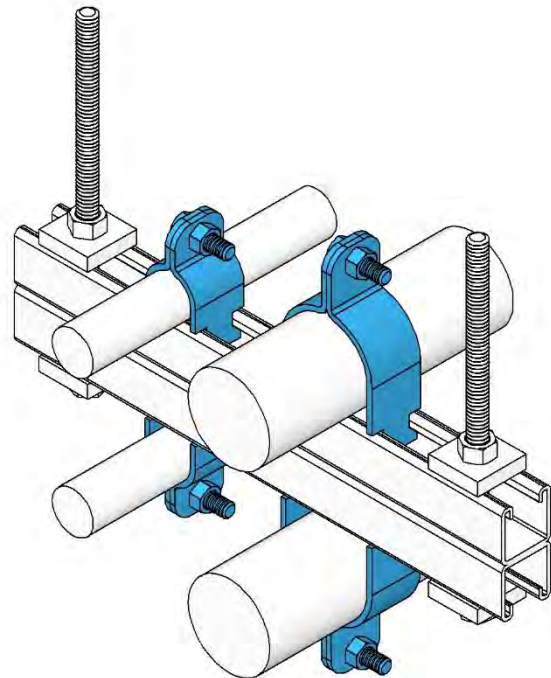
COPPER EPOXY STRUT PIPE CLAMP (FOR COPPER TUBING)

Part #	Conduit Size (in.)	O.D. (in.)	Design Load (lbs.)	Safety Factor	Approx. Wt. (lbs.)
A-910C 1/4	1/4	0.375	400	5.0	0.08
A-910C 3/8	3/8	0.500	400	5.0	0.08
A-910C 1/2	1/2	0.625	400	5.0	0.09
A-910C 3/4	3/4	0.875	600	5.0	0.11
A-910C 1	1	1.125	600	5.0	0.16
A-910C 1 1/4	1 1/4	1.375	600	5.0	0.17
A-910C 1 1/2	1 1/2	1.625	800	5.0	0.19
A-910C 2	2	2.125	800	5.0	0.21
A-910C 2 1/2	2 1/2	2.625	800	5.0	0.33
A-910C 3	3	3.125	800	5.0	0.37
A-910C 3 1/2	3 1/2	3.625	1000	5.0	0.43
A-910C 4	4	4.125	1000	5.0	0.45
A-910C 5	5	5.125	1000	5.0	0.62
A-910C 6	6	6.125	1000	5.0	0.90

Standard Trapeze Hanger



Double Trapeze Hanger



These specifications are for reference only. Aimco International Group Corp. reserves the right to make changes to the design without prior notice.

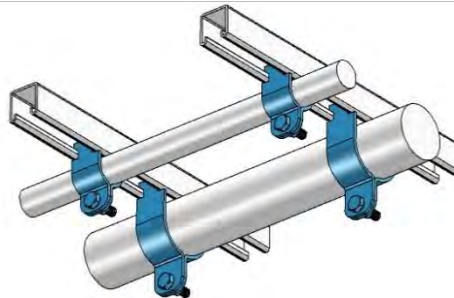
O.D. STRUT PIPE CLAMP

Part #	O.D. Size (in.)	Pipe Size (in.)	Design Load (lbs.)	Safety Factor	Approx. Wt. (lbs.)
A-9100D 1/4	1/4	1/8	400	5.0	0.08
A-9100D 3/8	3/8	1/4	400	5.0	0.08
A-9100D 1/2	1/2	3/8	400	5.0	0.08
A-9100D 5/8	5/8	1/2	400	5.0	0.09
A-9100D 3/4	3/4	5/8	400	5.0	0.11
A-9100D 7/8	7/8	3/4	400	5.0	0.11
A-9100D 1	1	7/8	600	5.0	0.13
A-9100D 1 1/8	1 1/8	1	600	5.0	0.15
A-9100D 1 1/4	1 1/4	1 1/8	600	5.0	0.16
A-9100D 1 3/8	1 3/8	1 1/4	600	5.0	0.17
A-9100D 1 1/2	1 1/2	1 3/8	600	5.0	0.18
A-9100D 1 5/8	1 5/8	1 1/2	600	5.0	0.19
A-9100D 1 3/4	1 3/4	1 5/8	800	5.0	0.19
A-9100D 1 7/8	1 7/8	1 3/4	800	5.0	0.28
A-9100D 2	2	1 7/8	800	5.0	0.31
A-9100D 2 1/8	2 1/8	2	800	5.0	0.31
A-9100D 2 1/4	2 1/4	2 1/8	800	5.0	0.33
A-9100D 2 3/8	2 3/8	2 1/4	800	5.0	0.34
A-9100D 2 1/2	2 1/2	2 3/8	800	5.0	0.35
A-9100D 2 5/8	2 5/8	2 1/2	800	5.0	0.39
A-9100D 2 3/4	2 3/4	2 5/8	800	5.0	0.39
A-9100D 2 7/8	2 7/8	2 3/4	800	5.0	0.39
A-9100D 3	3	2 7/8	800	5.0	0.41
A-9100D 3 1/8	3 1/8	3	800	5.0	0.42
A-9100D 3 1/4	3 1/4	3 1/8	800	5.0	0.42
A-9100D 3 3/8	3 3/8	3 1/4	800	5.0	0.43
A-9100D 3 1/2	3 1/2	3 3/8	800	5.0	0.44
A-9100D 3 5/8	3 5/8	3 1/2	1000	5.0	0.56
A-9100D 3 3/4	3 3/4	3 5/8	1000	5.0	0.57
A-9100D 3 7/8	3 7/8	3 3/4	1000	5.0	0.57
A-9100D 4	4	3 7/8	1000	5.0	0.61
A-9100D 4 1/8	4 1/8	4	1000	5.0	0.61
A-9100D 4 1/4	4 1/4	4 1/8	1000	5.0	0.64
A-9100D 4 3/8	4 3/8	4 1/4	1000	5.0	0.64
A-9100D 4 1/2	4 1/2	4 3/8	1000	5.0	0.66
A-9100D 4 5/8	4 5/8	4 1/2	1000	5.0	0.66
A-9100D 4 3/4	4 3/4	4 5/8	1000	5.0	0.68
A-9100D 4 7/8	4 7/8	4 3/4	1000	5.0	0.73
A-9100D 5	5	4 7/8	1000	5.0	0.74
A-9100D 5 1/8	5 1/8	5	1000	5.0	0.70
A-9100D 5 1/4	5 1/4	5 1/8	1000	5.0	0.70

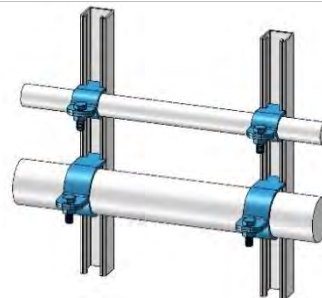
These specifications are for reference only. Aimco International Group Corp. reserves the right to make changes to the design without prior notice.

A-9100D 5 3/8	5 3/8	5 1/4	1000	5.0	0.77
A-9100D 5 1/2	5 1/2	5 3/8	1000	5.0	0.78
A-9100D 5 5/8	5 5/8	5 1/2	1000	5.0	0.83
A-9100D 5 3/4	5 3/4	5 5/8	1000	5.0	0.84
A-9100D 5 7/8	5 7/8	5 3/4	1000	5.0	0.85
A-9100D 6	6	5 7/8	1000	5.0	0.94
A-9100D 6 1/8	6 1/8	6	1000	5.0	0.94
A-9100D 6 1/4	6 1/4	6 1/8	1000	5.0	0.96
A-9100D 6 3/8	6 3/8	6 1/4	1000	5.0	0.98
A-9100D 6 1/2	6 1/2	6 3/8	1000	5.0	0.99
A-9100D 6 5/8	6 5/8	6 1/2	1000	5.0	1.00
A-9100D 6 3/4	6 3/4	6 5/8	1000	5.0	1.02
A-9100D 6 7/8	6 7/8	6 3/4	1000	5.0	1.04
A-9100D 7	7	6 7/8	1000	5.0	1.08
A-9100D 7 1/8	7 1/8	7	1000	5.0	1.08
A-9100D 7 1/4	7 1/4	7 1/8	1000	5.0	1.10
A-9100D 7 3/8	7 3/8	7 1/4	1000	5.0	1.12
A-9100D 7 1/2	7 1/2	7 3/8	1000	5.0	1.13
A-9100D 7 5/8	7 5/8	7 1/2	1000	5.0	1.15
A-9100D 7 3/4	7 3/4	7 5/8	1000	5.0	1.17
A-9100D 7 7/8	7 7/8	7 3/4	1000	5.0	1.19
A-9100D 8	8	7 7/8	1000	5.0	1.21

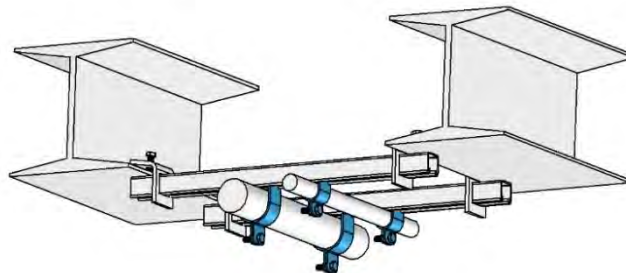
Ceiling Mounting



Wall Mounting

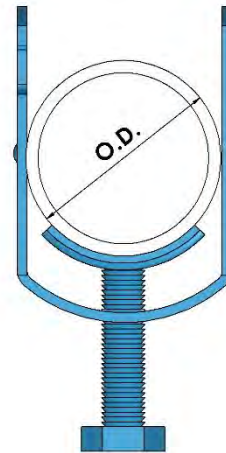


Beam Mounting

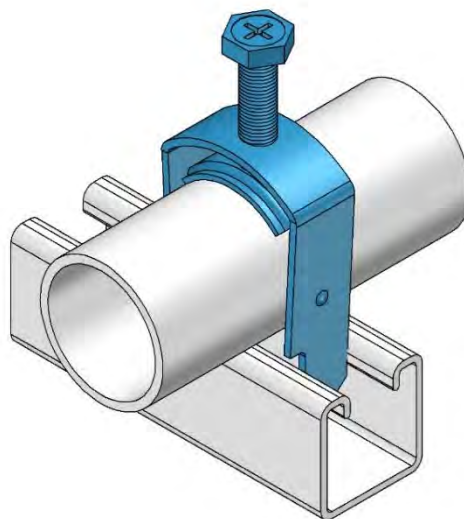


These specifications are for reference only. Aimco International Group Corp. reserves the right to make changes to the design without prior notice.

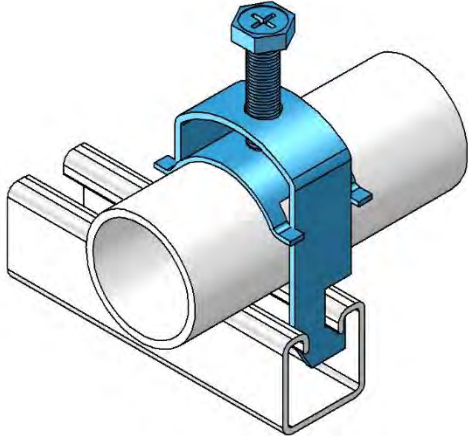
SINGLE PIECE STRUT CLAMP (SCH SERIES)



Part #	O.D. Range (in.)	EMT Conduit Size (in.)	Rigid Conduit & Pipe Size (in.)	Static Load (lbs.)	Approx. Wt. (lbs.)
A-CAD SCH6B	0.10 - 0.63	-	-	200	0.06
A-CAD SCH8B	0.34 - 0.71	1/2	-	200	0.06
A-CAD SCH12B	0.57 - 0.92	3/4	1/2	200	0.07
A-CAD SCH16B	0.72 - 1.16	1	3/4	200	0.08
A-CAD SCH20B	1.00 - 1.51	1 1/4	1	200	0.09
A-CAD SCH24B	1.25 - 1.74	1 1/2	1 1/4	350	0.16
A-CAD SCH32B	1.74 - 2.20	2	1 1/2	350	0.20
A-CAD SCH40B	2.00 - 2.38	-	2	350	0.21
A-CAD SCH48B	2.38 - 2.88	2 1/2	2 1/2	350	0.25
A-CAD SCH56B	2.72 - 3.50	3	3	350	0.29
A-CAD SCH64B	3.25 - 4.00	3 1/2	3 1/2	350	0.32
A-CAD SCH72B	3.85 - 4.50	4	4	350	0.37



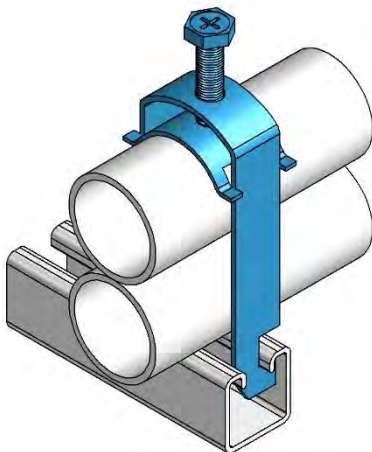
These specifications are for reference only. Aimco International Group Corp. reserves the right to make changes to the design without prior notice.



CABLE CLAMP

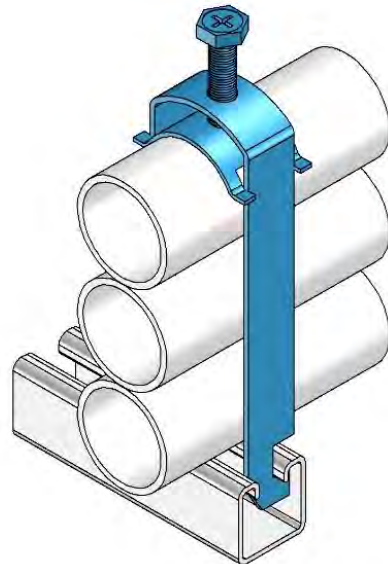
Part #	O.D. Range (in.)	Min. Rigid Conduit (in.)	Max. Rigid Conduit (in.)	EMT Conduit (in.)	Approx. Wt. (lbs.)
A-055	0.050 - 0.625	-	-	3/8	0.08
A-081	0.310 - 0.875	3/8	1/2	3/8 - 1/2	0.09
A-125	0.750 - 1.313	1/2	3/4	3/4 - 1	0.12
A-135	0.850 - 1.375	3/4	1	3/4 - 1	0.13
A-175	1.250 - 1.875	1	1 1/4	1 1/4 - 1 1/2	0.14
A-225	1.750 - 2.250	1 1/2	1 1/2	2	0.28
A-275	2.250 - 2.875	2	2 1/2	-	0.34
A-325	2.750 - 3.250	2 1/2	2 1/2	-	0.38
A-375	3.250 - 3.813	3	3	-	0.43
A-425	3.750 - 4.500	3 1/2	4	-	0.49
A-475	4.250 - 4.938	4	4	-	0.52

CABLE CLAMP DOUBLE



Available in the above listed sizes. Add suffix D to the Part # for the matching O.D. Range in the table above.

CABLE CLAMP TRIPLE



Available in the above listed sizes. Add suffix T to the Part # for the matching O.D. Range in the table above.

These specifications are for reference only. Aimco International Group Corp. reserves the right to make changes to the design without prior notice.

Section 3: Trolleys

FUNCTIONS AND FEATURES

Trolley system offers important advantages over other systems, they offer greater efficiency, better economy and easier installation. The returned edge of the channel forms a strong, low-friction bearing surface for the trolleys to travel the full length of the channel track.

Trolleys are designed to move equipments from 10 up to 600 pounds. They are engineered to deliver built-in value and dependability for a wide range of applications including: pneumatic tools, lubrication systems, rolling doors, die handling, curtain fixtures, material transfer and other applications.

MATERIAL

Carbon Steel (ASTM A1011)

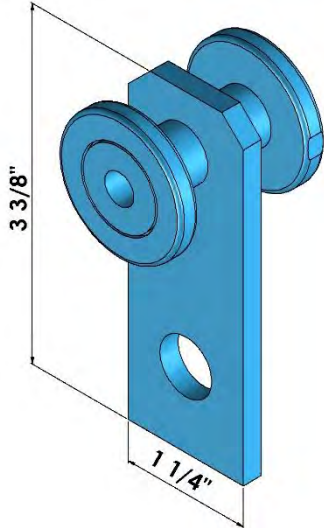
FINISH

Zinc Electro-Galvanized (ASTM B633)

NOTE

FPM = Feet Per Minute

RPM = Revolutions Per Minute

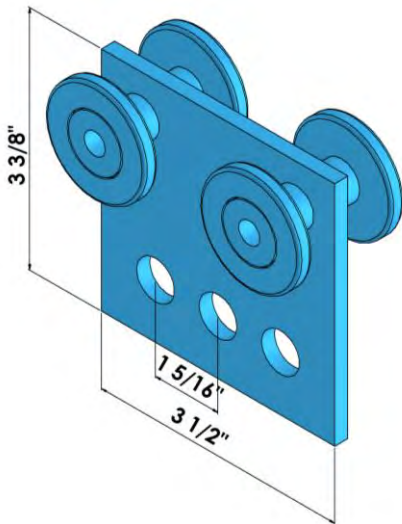


TWO WHEEL PLATE TROLLEY

Part # | A-2521

Specification Data	
Hole Dia. (in.)	9/16
Hole Spacing from End (in.)	13/16
Approx. Wt. (lbs.)	0.47
Note	Vertical measurement includes wheels where applicable

FPM	RPM	Design Load (lbs.)
180	600	150
90	300	225
30	100	437

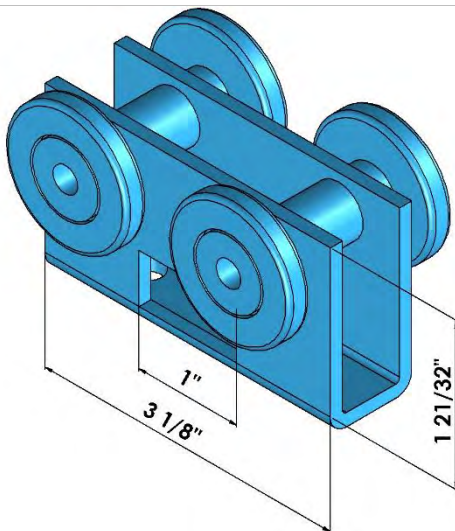


FOUR WHEEL PLATE TROLLEY

Part # | A-2522

Specification Data	
Hole Dia. (in.)	9/16
Hole Spacing from End (in.)	13/16
Approx. Wt. (lbs.)	1.13
Note	Vertical measurement includes wheels where applicable

FPM	RPM	Design Load (lbs.)
180	600	300
90	300	450
30	100	600

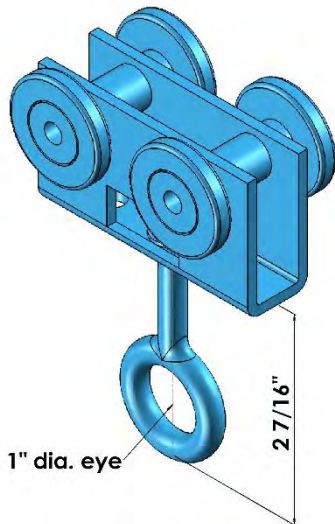


FOUR WHEEL U BODY TROLLEY

Part # | A-2524

Specification Data	
Hole Dia. (in.)	9/32
Slots Dia. (in.)	9/16 x 9/32
Design Load (lbs.)	100
Approx. Wt. (lbs.)	0.53
Note	Vertical measurement includes wheels where applicable

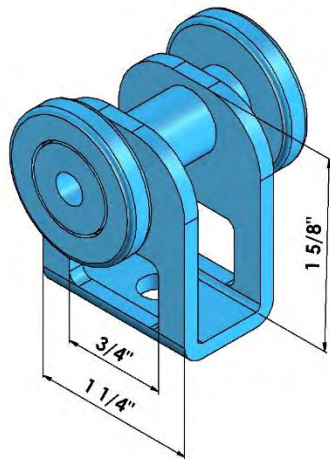
These specifications are for reference only. Aimco International Group Corp. reserves the right to make changes to the design without prior notice.



FOUR WHEEL U BODY TROLLEY WITH EYE BOLT

Part # | A-2524EB

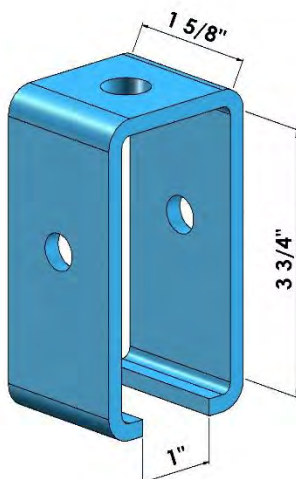
Specification Data	
Hole Dia. (in.)	9/32
Slots Dia. (in.)	9/16 x 9/32
Design Load (lbs.)	100
Approx. Wt. (lbs.)	0.67
Note	Vertical measurement includes wheels where applicable



TWO WHEEL U BODY TROLLEY

Part # | A-2525

Specification Data	
Hole Dia. (in.)	9/32
Design Load (lbs.)	50
Approx. Wt. (lbs.)	0.23
Note	Vertical measurement includes wheels where applicable

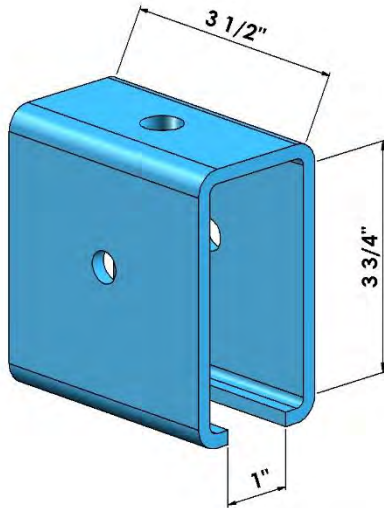


TROLLEY SUPPORT SPLICE

Part # | A-2528

Specification Data	
Top Hole Dia. (in.)	9/16
Side Holes Dia. (in.)	7/16
Design Load (lbs.)	1200
Approx. Wt. (lbs.)	1.02
Note	Used on the outside of strut channel. Requires 3/8" x 2 1/2" bolt and 3/8" nut (not included)

These specifications are for reference only. Aimco International Group Corp. reserves the right to make changes to the design without prior notice.



TROLLEY SUPPORT SPLICE HEAVY DUTY

Part # | A-2529

Specification Data

Top Hole Dia. (in.)	9/16
Side Holes Dia. (in.)	7/16
Design Load (lbs.)	2500
Approx. Wt. (lbs.)	2.20
Note	Used on the outside of strut channel. Requires 3/8" x 2 1/2" bolt and 3/8" nut (not included)

These specifications are for reference only. Aimco International Group Corp. reserves the right to make changes to the design without prior notice.

Section 4: Combo Nut Washer & Spring Nuts

FUNCTIONS AND FEATURES

Combo Nut Washer is a pre-assembled nut and washer, which helps reduce the number of parts that require handling. The combination design allows for easy adjustment when installed in strut channel, and provides quick attachment for threaded rod, allowing a simple installation using just one hand, which helps reduce installation time and cost. Furthermore, the serrated flange negates the need for a flat washer.

To install, position Combo Nut Washer into strut channel and rotate clockwise as nut seats in the strut channel. Then slide Combo Nut Washer into the desired location in the strut channel and insert threaded rod into nut, the Combo Nut Washer locks at 90 degree angle. Then thread the rod up through the nut and lock into place with a hex nut, now the threaded rod is ready for products to be installed.

Spring Nuts are one of the main components of the suspension system, they are inserted anywhere along the continuous slot of the channel, allowing the attachment of fittings without drilling or welding. If changes are required, fittings are easily adjusted, removed, or reused.

Designed with specially formed teeth in the parallel channel recesses to grip the returned edge of the channel, and the shearing action of the teeth assures positive locking of the channel to the fittings.

Spring Nuts with regular spring have shrink wrap sleeves on them eliminating tangling during shipping and installation.

MATERIAL

Mild Steel (ASTM A108)

CASE HARDENING

After stamping and machining operations are completed, Spring Nuts are case hardened to a depth of 0.003" to 0.005" conforming to ASTM A576/A108 Grade 1015.

THREADS

Conforms to Unified Screw Thread(UNC) standard, ANSI B1.1, coarse series UNC Class 2

FINISHES

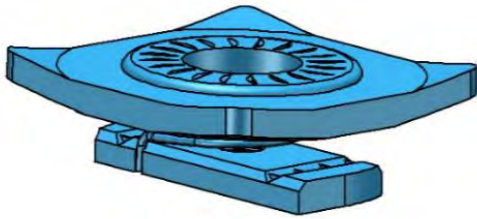
Zinc Electro-Galvanized (ASTM B633)

Hot-Dip Galvanized (ASTM A123/A153)

STAINLESS STEEL OPTIONS

All Spring Nuts are available in 304 Stainless Steel or 316 Stainless Steel (ASTM A240)

These specifications are for reference only. Aimco International Group Corp. reserves the right to make changes to the design without prior notice.

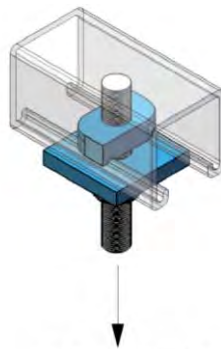


COMBO NUT WASHER

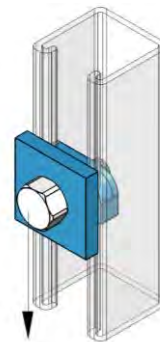
Part #	Thread Size (in.)	Dim. of Washer (in.)	Thread Count	Nut Thickness (in.)	Torque (ft.-lbs.)	Safety Factor	Approx. Wt. (lbs.)
A-NW524	1/4	1 5/8 x 1 5/8	20	1/4	6	3	0.16
A-NW528	3/8	1 5/8 x 1 5/8	16	3/8	19	3	0.18
A-NW525	1/2	1 5/8 x 1 5/8	13	3/8	50	3	0.17

Pull-Out and Resistance to Slip Loads

Thread Size	12 Gauge Strut		14 Gauge Strut		16 Gauge Strut	
	Max. Allowable Pull-Out Strength (lbs.)	Resistance to Slip (lbs.)	Max. Allowable Pull-Out Strength (lbs.)	Resistance to Slip (lbs.)	Max. Allowable Pull-Out Strength (lbs.)	Resistance to Slip (lbs.)
1/4"-20	450	300	450	300	450	300
3/8"-16	1100	800	1000	600	1000	600
1/2"-13	1500	1500	1400	1000	1000	1000

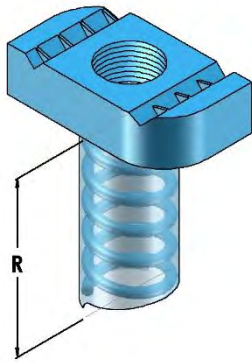


Pull-Out Strength



Resistance to Slip

These specifications are for reference only. Aimco International Group Corp. reserves the right to make changes to the design without prior notice.

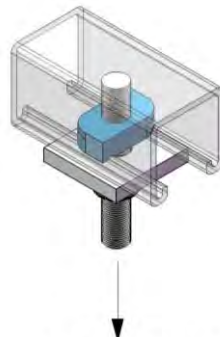


SPRING NUT REGULAR SPRING (WITH SHRINK WRAP)

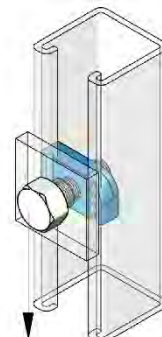
Part #	Thread Size (in.)	Thread Count	R (in.)	Thickness (in.)	Torque (ft.-lbs.)	Safety Factor	Approx. Wt. (lbs.)
A-900RG 1/4	1/4	20	1 1/2	1/4	6	3	0.07
A-900RG 5/16	5/16	18	1 1/2	3/8	11	3	0.09
A-900RG 3/8	3/8	16	1 1/2	3/8	19	3	0.09
A-900RG 1/2	1/2	13	1 1/2	3/8	50	3	0.08
A-900RG 1/2 x 1/2	1/2	13	1 1/2	1/2	80	3	0.11
A-900RG 5/8	5/8	11	1 1/2	1/2	100	3	0.14
A-900RG 3/4	3/4	10	1 1/2	1/2	125	3	0.15
A-900RG 7/8	7/8	9	1 1/2	1/2	125	3	0.13

Pull-Out and Resistance to Slip Loads

Thread Size	12 Gauge Strut		14 Gauge Strut		16 Gauge Strut	
	Max. Allowable Pull-Out Strength (lbs.)	Resistance to Slip (lbs.)	Max. Allowable Pull-Out Strength (lbs.)	Resistance to Slip (lbs.)	Max. Allowable Pull-Out Strength (lbs.)	Resistance to Slip (lbs.)
1/4"-20	600	300	600	300	600	300
5/16"-18	800	500	800	400	800	400
3/8"-16	1000	800	1000	750	1000	750
1/2"-13	2000	1500	1400	1000	1000	1000
1/2"x1/2"-13	2300	1500	1400	1000	1000	1000
5/8"-11	2500	1500	1400	1000	1000	1000
3/4"-10	2500	1700	1400	1000	1000	1000
7/8"-9	2500	1700	1400	1000	1000	1000

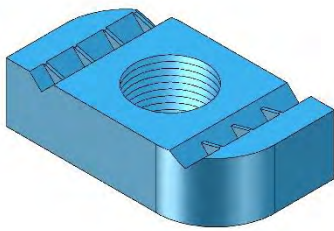


Pull-Out Strength



Resistance to Slip

These specifications are for reference only. Aimco International Group Corp. reserves the right to make changes to the design without prior notice.

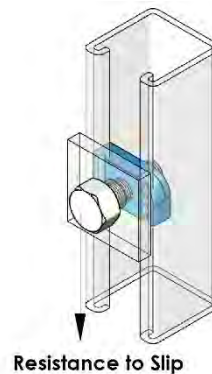
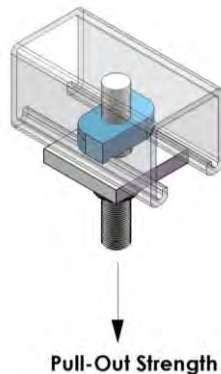


SPRING NUT NO SPRING

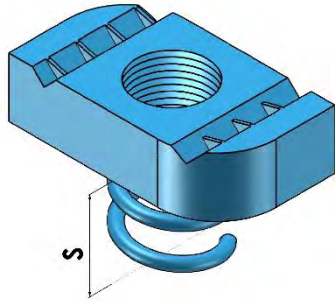
Part #	Thread Size (in.)	Thread Count	Thickness (in.)	Torque (ft.-lbs.)	Safety Factor	Approx. Wt. (lbs.)
A-900NS 1/4	1/4	20	1/4	6	3	0.06
A-900NS 5/16	5/16	18	3/8	11	3	0.09
A-900NS 3/8	3/8	16	3/8	19	3	0.08
A-900NS 1/2	1/2	13	3/8	50	3	0.07
A-900NS 1/2 x 1/2	1/2	13	1/2	80	3	0.10
A-900NS 5/8	5/8	11	1/2	100	3	0.13
A-900NS 3/4	3/4	10	1/2	125	3	0.13
A-900NS 7/8	7/8	9	1/2	125	3	0.12

Pull-Out and Resistance to Slip Loads

Thread Size	12 Gauge Strut		14 Gauge Strut		16 Gauge Strut	
	Max. Allowable Pull-Out Strength (lbs.)	Resistance to Slip (lbs.)	Max. Allowable Pull-Out Strength (lbs.)	Resistance to Slip (lbs.)	Max. Allowable Pull-Out Strength (lbs.)	Resistance to Slip (lbs.)
1/4"-20	600	300	600	300	600	300
5/16"-18	800	500	800	400	800	400
3/8"-16	1000	800	1000	750	1000	750
1/2"-13	2000	1500	1400	1000	1000	1000
1/2"x1/2"-13	2300	1500	1400	1000	1000	1000
5/8"-11	2500	1500	1400	1000	1000	1000
3/4"-10	2500	1700	1400	1000	1000	1000
7/8"-9	2500	1700	1400	1000	1000	1000



These specifications are for reference only. Aimco International Group Corp. reserves the right to make changes to the design without prior notice.

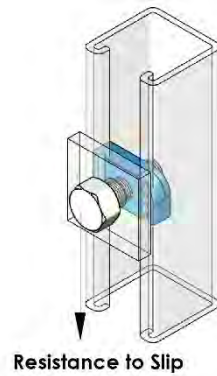
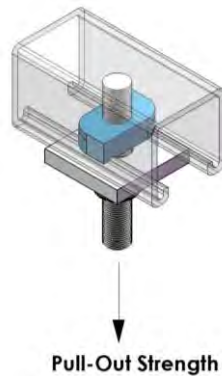


SPRING NUT SHORT SPRING

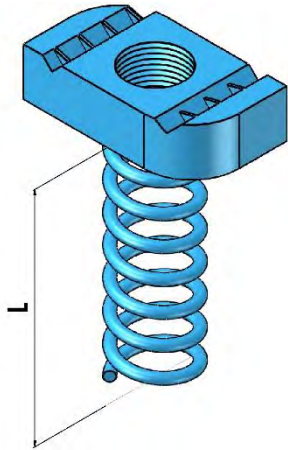
Part #	Thread Size (in.)	Thread Count	S (in.)	Thickness (in.)	Torque (ft.-lbs.)	Safety Factor	Approx. Wt. (lbs.)
A-900SH 1/4	1/4	20	11/16	1/4	6	3	0.06
A-900SH 5/16	5/16	18	11/16	3/8	11	3	0.09
A-900SH 3/8	3/8	16	11/16	3/8	19	3	0.08
A-900SH 1/2	1/2	13	11/16	3/8	50	3	0.07
A-900SH 1/2 x 1/2	1/2	13	11/16	1/2	80	3	0.10
A-900SH 5/8	5/8	11	11/16	1/2	100	3	0.14
A-900SH 3/4	3/4	10	11/16	1/2	125	3	0.13
A-900SH 7/8	7/8	9	11/16	1/2	125	3	0.12

Pull-Out and Resistance to Slip Loads

Thread Size	12 Gauge Strut		14 Gauge Strut		16 Gauge Strut	
	Max. Allowable Pull-Out Strength (lbs.)	Resistance to Slip (lbs.)	Max. Allowable Pull-Out Strength (lbs.)	Resistance to Slip (lbs.)	Max. Allowable Pull-Out Strength (lbs.)	Resistance to Slip (lbs.)
1/4"-20	600	300	600	300	600	300
5/16"-18	800	500	800	400	800	400
3/8"-16	1000	800	1000	750	1000	750
1/2"-13	2000	1500	1400	1000	1000	1000
1/2"x1/2"-13	2300	1500	1400	1000	1000	1000
5/8"-11	2500	1500	1400	1000	1000	1000
3/4"-10	2500	1700	1400	1000	1000	1000
7/8"-9	2500	1700	1400	1000	1000	1000



These specifications are for reference only. Aimco International Group Corp. reserves the right to make changes to the design without prior notice.

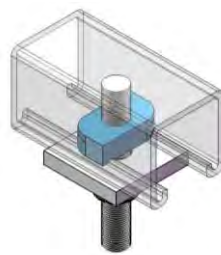


SPRING NUT LONG SPRING

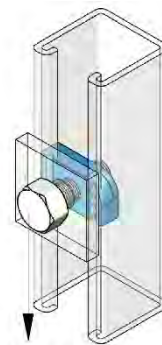
Part #	Thread Size (in.)	Thread Count	L (in.)	Thickness (in.)	Torque (ft.-lbs.)	Safety Factor	Approx. Wt. (lbs.)
A-900LS 1/4	1/4	20	2 1/2	1/4	6	3	0.07
A-900LS 5/16	5/16	18	2 1/2	3/8	11	3	0.09
A-900LS 3/8	3/8	16	2 1/2	3/8	19	3	0.09
A-900LS 1/2	1/2	13	2 1/2	3/8	50	3	0.08
A-900LS 1/2 x 1/2	1/2	13	2 1/2	1/2	80	3	0.10
A-900LS 5/8	5/8	11	2 1/2	1/2	100	3	0.15
A-900LS 3/4	3/4	10	2 1/2	1/2	125	3	0.14
A-900LS 7/8	7/8	9	2 1/2	1/2	125	3	0.13

Pull-Out and Resistance to Slip Loads

Thread Size	12 Gauge Strut		14 Gauge Strut		16 Gauge Strut	
	Max. Allowable Pull-Out Strength (lbs.)	Resistance to Slip (lbs.)	Max. Allowable Pull-Out Strength (lbs.)	Resistance to Slip (lbs.)	Max. Allowable Pull-Out Strength (lbs.)	Resistance to Slip (lbs.)
1/4"-20	600	300	600	300	600	300
5/16"-18	800	500	800	400	800	400
3/8"-16	1000	800	1000	750	1000	750
1/2"-13	2000	1500	1400	1000	1000	1000
1/2"x1/2"-13	2300	1500	1400	1000	1000	1000
5/8"-11	2500	1500	1400	1000	1000	1000
3/4"-10	2500	1700	1400	1000	1000	1000
7/8"-9	2500	1700	1400	1000	1000	1000



Pull-Out Strength



Resistance to Slip

These specifications are for reference only. Aimco International Group Corp. reserves the right to make changes to the design without prior notice.

Section 5: General Fittings

FUNCTIONS AND FEATURES

Strut Fittings are strong, quick, economical and adjustable, they provide a unique weldless connection method to the metal framing system. A typical method of connecting a strut fitting to the strut channel is to insert the spring nut anywhere along the continuous slotted channel. The rounded spring nut ends permit easy insertion. Then a 90° clockwise turn aligns the grooves in the spring nut with the returned edge of the channel. Strut Fittings can be placed anywhere along the channel opening, permitting complete freedom of adjustment. Insert the bolt through the fitting and into the spring nut, additional channel sections can now be bolted to the fitting already in place. Tightening with a wrench locks the serrated teeth of the spring nut into the returned edge of the channel, completing a strong, vise-like connection.

Part drawings illustrate only one application or function of each fitting. In most cases many other applications are possible. The channels shown in the illustrations are 1 5/8" wide, except where noted otherwise.

Strut Fittings are designed to fit with all sizes of 1 5/8" wide channels. Unless otherwise specified, fittings are manufactured from 1/4" thick carbon steel, 1 5/8" wide, all holes are 9/16" diameter, spaced 1 7/8" on center, and 13/16" from the end.

MATERIALS

Hot-Rolled Steel (ASTM A1011/A1018)

Stainless Steel - Type 304 or 316 (ASTM A240)

FINISHES

Hot-Dip Galvanized (ASTM A123)

Zinc Electro-Galvanized (ASTM B633)

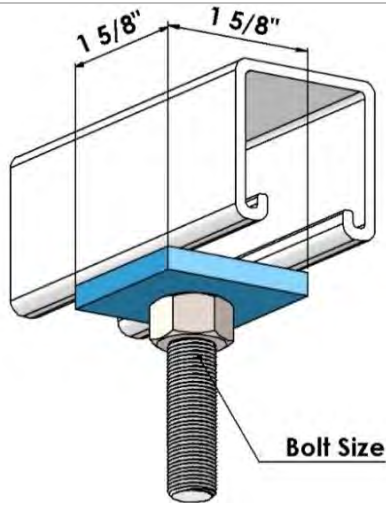
STAINLESS STEEL OPTIONS

All Strut Fittings are available in 304 Stainless Steel or 316 Stainless Steel (ASTM A240)

NOTE

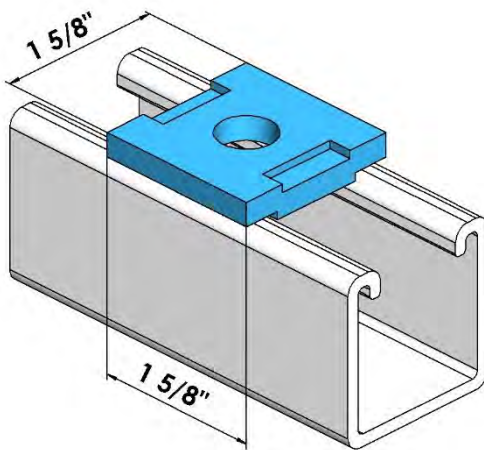
The more popular Strut Fittings are illustrated on the following pages. However, there are many other fittings available. Please contact us for any other fittings you may need for specific applications.

SQUARE WASHERS



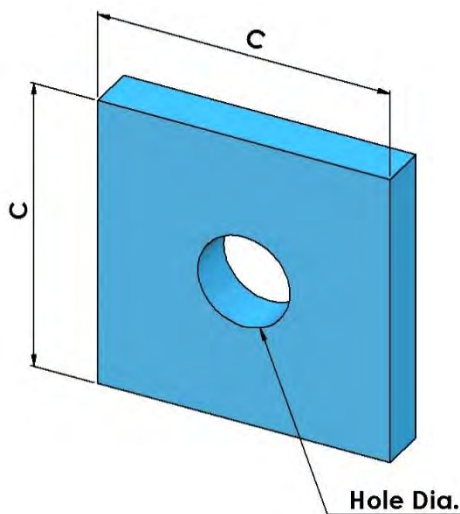
SQUARE WASHER

Part #	Bolt Size (in.)	Hole Dia. (in.)	Approx. Wt. (lbs.)
A-619	1/4	5/16	0.16
A-6195	5/16	3/8	0.16
A-620	3/8	7/16	0.15
A-621	1/2	9/16	0.15
A-622	5/8	11/16	0.14
A-623	3/4	13/16	0.13



SQUARE WASHER NO TWIST

Part #	Bolt Size (in.)	Hole Dia. (in.)	Approx. Wt. (lbs.)
A-619NT	1/4	5/16	0.16
A-6195NT	5/16	3/8	0.16
A-620NT	3/8	7/16	0.15
A-621NT	1/2	9/16	0.15
A-622NT	5/8	11/16	0.14
A-623NT	3/4	13/16	0.13

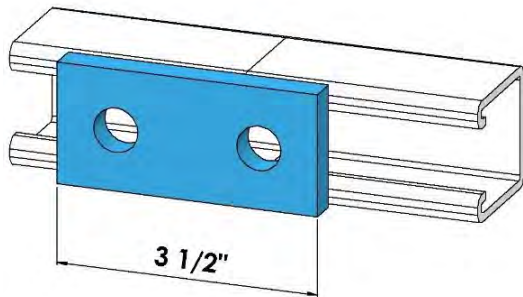


STEEL WASHER PLATE

Part #	C x C (in.)	Rod Size (in.)	Hole Dia. (in.)	Approx. Wt. (lbs.)
A-2x2 7/16	2 x 2	3/8	7/16	0.26
A-2x2 9/16	2 x 2	1/2	9/16	0.26
A-2x2 11/16	2 x 2	5/8	11/16	0.26
A-2x2 13/16	2 x 2	3/4	13/16	0.26
A-3x3 7/16	3 x 3	3/8	7/16	0.57
A-3x3 9/16	3 x 3	1/2	9/16	0.57
A-3x3 11/16	3 x 3	5/8	11/16	0.57
A-3x3 13/16	3 x 3	3/4	13/16	0.57
A-4x4 7/16	4 x 4	3/8	7/16	1.04
A-4x4 9/16	4 x 4	1/2	9/16	1.04
A-4x4 11/16	4 x 4	5/8	11/16	1.04
A-4x4 13/16	4 x 4	3/4	13/16	1.04

These specifications are for reference only. Aimco International Group Corp. reserves the right to make changes to the design without prior notice.

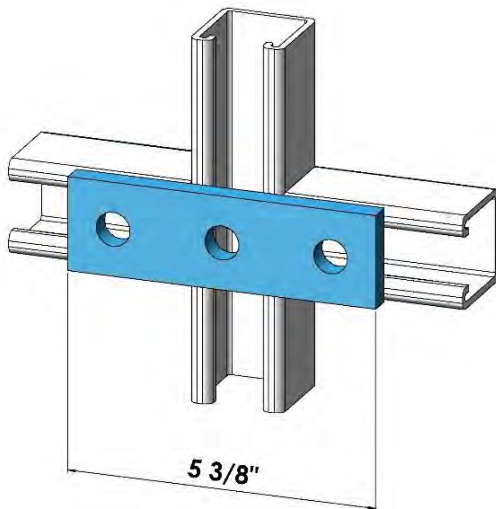
SPLICING CONNECTIONS



TWO HOLE SPLICE PLATE

Part # | A-601

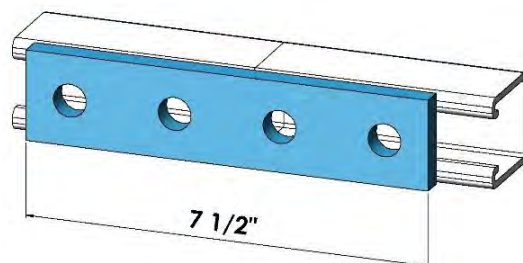
Specification Data	
Hole Dia. (in.)	9/16
Hole Spacing from End (in.)	13/16
Hole Spacing on Center (in.)	1 7/8
Width (in.)	1 5/8
Thickness (in.)	1/4
Approx. Wt. (lbs.)	0.35



THREE HOLE SPLICE PLATE

Part # | A-602

Specification Data	
Hole Dia. (in.)	9/16
Hole Spacing from End (in.)	13/16
Hole Spacing on Center (in.)	1 7/8
Width (in.)	1 5/8
Thickness (in.)	1/4
Approx. Wt. (lbs.)	0.53

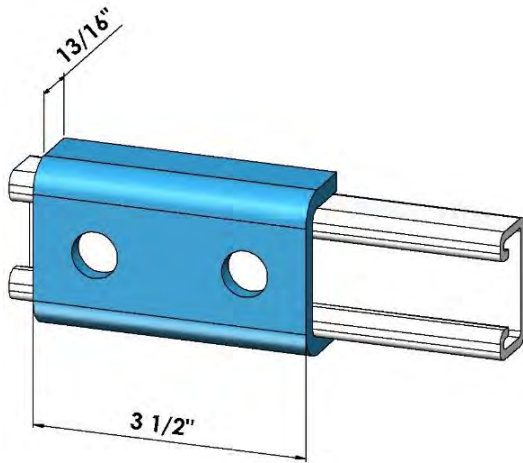


FOUR HOLE SPLICE PLATE

Part # | A-723

Specification Data	
Hole Dia. (in.)	9/16
Hole Spacing from End (in.)	13/16
Hole Spacing on Center (in.)	1 7/8
Width (in.)	1 5/8
Thickness (in.)	1/4
Approx. Wt. (lbs.)	0.70

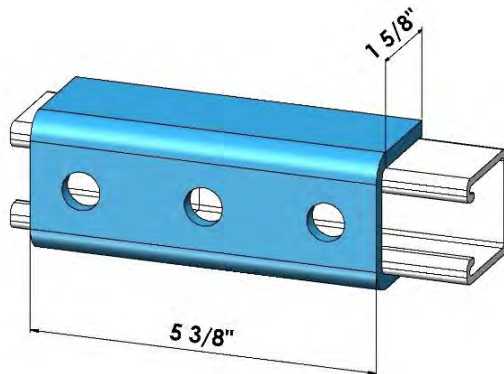
These specifications are for reference only. Aimco International Group Corp. reserves the right to make changes to the design without prior notice.



TWO HOLE SPLICE

Part # | A-409U

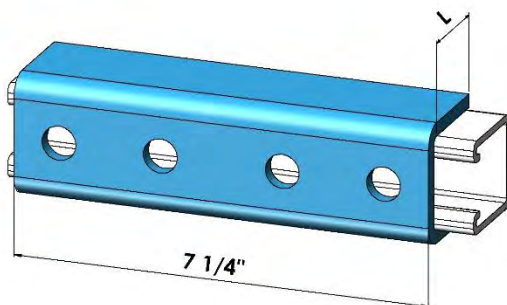
Specification Data	
Hole Dia. (in.)	9/16
Hole Spacing from End (in.)	13/16
Hole Spacing on Center (in.)	1 7/8
Width (in.)	1 5/8
Thickness (in.)	1/4
Approx. Wt. (lbs.)	0.68



THREE HOLE SPLICE

Part # | A-412U

Specification Data	
Hole Dia. (in.)	9/16
Hole Spacing from End (in.)	13/16
Hole Spacing on Center (in.)	1 7/8
Width (in.)	1 5/8
Thickness (in.)	1/4
Approx. Wt. (lbs.)	1.86

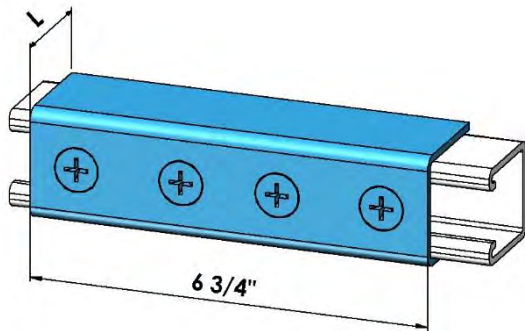


FOUR HOLE SPLICE

Part #	L (in.)	Approx. Wt. (lbs.)
A-616 1 5/8	1 5/8	2.56
A-616 1	1	1.67

Specification Data	
Hole Dia. (in.)	9/16
Hole Spacing from End (in.)	13/16
Hole Spacing on Center (in.)	1 7/8
Width (in.)	1 5/8
Thickness	11Ga

These specifications are for reference only. Aimco International Group Corp. reserves the right to make changes to the design without prior notice.



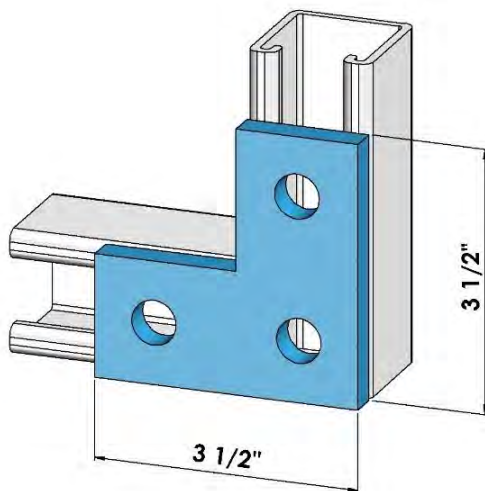
U SHAPE STRUT SPLICE (WITH NUTS)

Part #	L (in.)	Approx. Wt. (lbs.)
A-649 1 5/8	1 5/8	0.83
A-649 13/16	13/16	0.65

Specification Data

Hole Dia. (in.)	9/16
Hole Spacing from End (in.)	13/16
Hole Spacing on Center (in.)	1 7/8
Width (in.)	1 5/8
Thickness	16Ga
Note	Supplied with four 1/4" x 5/8" Flat Head Machine Screws and four 1/4" Spring Nuts No Spring

CORNER CONNECTIONS



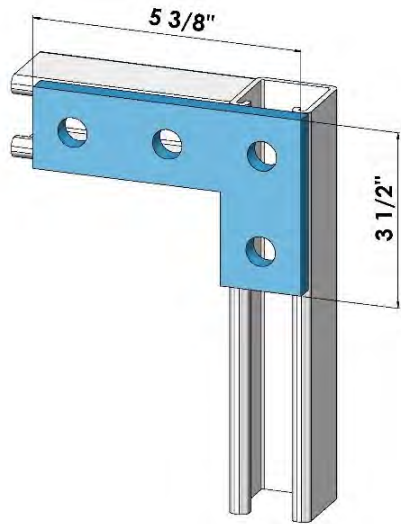
THREE HOLE FLAT PLATE

Part # | A-718

Specification Data

Hole Dia. (in.)	9/16
Hole Spacing from End (in.)	13/16
Hole Spacing on Center (in.)	1 7/8
Width (in.)	1 5/8
Thickness (in.)	1/4
Approx. Wt. (lbs.)	0.44

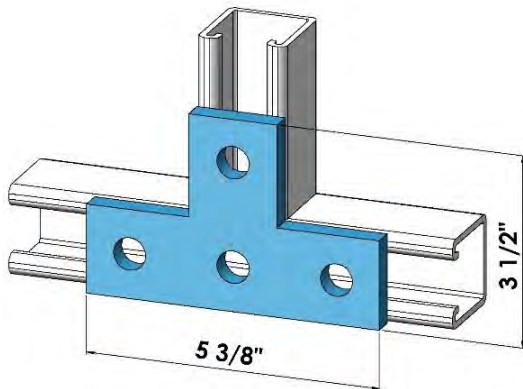
These specifications are for reference only. Aimco International Group Corp. reserves the right to make changes to the design without prior notice.



FOUR HOLE FLAT PLATE

Part # | A-123P

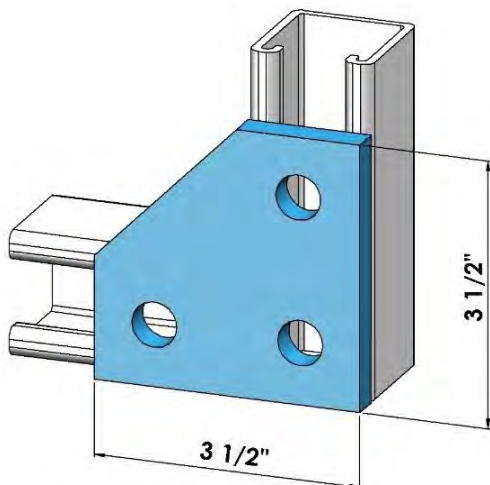
Specification Data	
Hole Dia. (in.)	9/16
Hole Spacing from End (in.)	13/16
Hole Spacing on Center (in.)	1 7/8
Width (in.)	1 5/8
Thickness (in.)	1/4
Approx. Wt. (lbs.)	0.70



TEE PLATE

Part # | A-714

Specification Data	
Hole Dia. (in.)	9/16
Hole Spacing from End (in.)	13/16
Hole Spacing on Center (in.)	1 7/8
Width (in.)	1 5/8
Thickness (in.)	1/4
Approx. Wt. (lbs.)	0.70

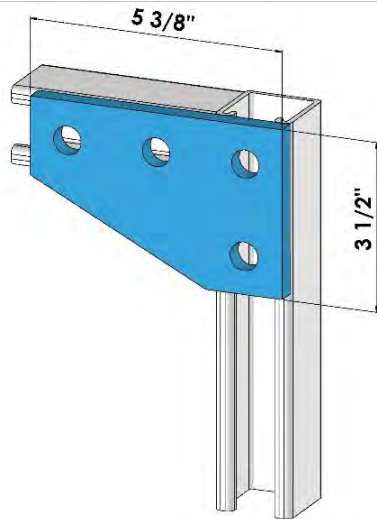


THREE HOLE CORNER PLATE

Part # | A-744

Specification Data	
Hole Dia. (in.)	9/16
Hole Spacing from End (in.)	13/16
Hole Spacing on Center (in.)	1 7/8
Width (in.)	1 5/8
Thickness (in.)	1/4
Approx. Wt. (lbs.)	0.63

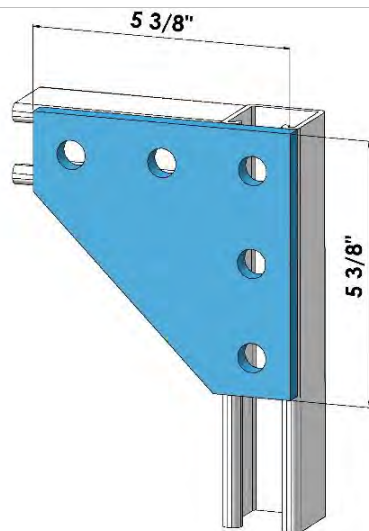
These specifications are for reference only. Aimco International Group Corp. reserves the right to make changes to the design without prior notice.



FOUR HOLE CORNER PLATE

Part # | A-750

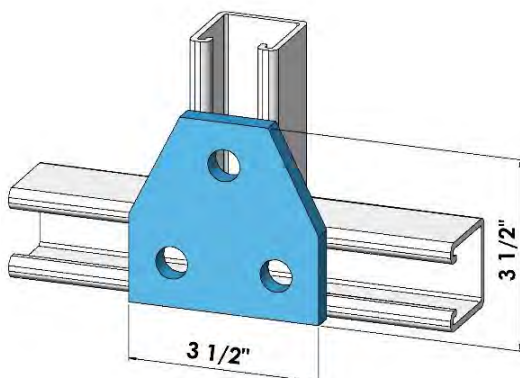
Specification Data	
Hole Dia. (in.)	9/16
Hole Spacing from End (in.)	13/16
Hole Spacing on Center (in.)	1 7/8
Width (in.)	1 5/8
Thickness (in.)	1/4
Approx. Wt. (lbs.)	0.92



FIVE HOLE CORNER PLATE

Part # | A-751

Specification Data	
Hole Dia. (in.)	9/16
Hole Spacing from End (in.)	13/16
Hole Spacing on Center (in.)	1 7/8
Width (in.)	1 5/8
Thickness (in.)	1/4
Approx. Wt. (lbs.)	1.32

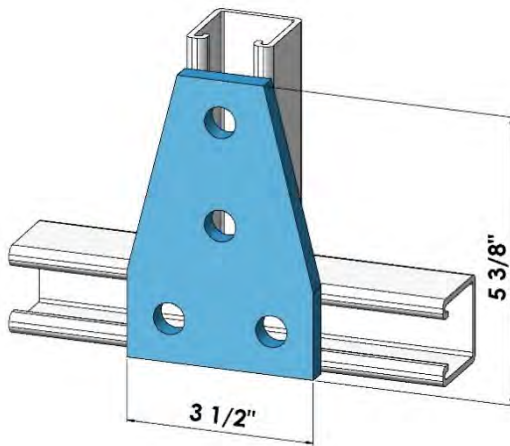


THREE HOLE TEE PLATE

Part # | A-925

Specification Data	
Hole Dia. (in.)	9/16
Hole Spacing from End (in.)	13/16
Hole Spacing on Center (in.)	1 7/8
Width (in.)	1 5/8
Thickness (in.)	1/4
Approx. Wt. (lbs.)	0.65

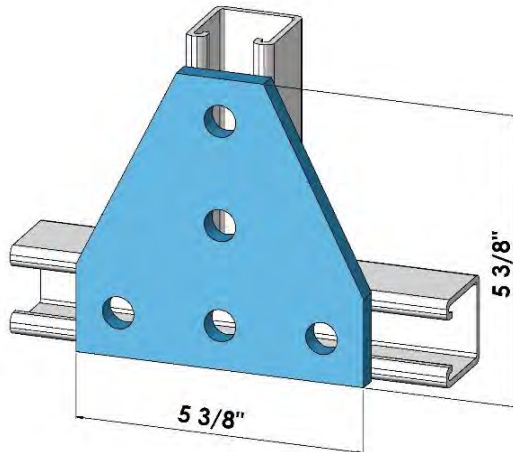
These specifications are for reference only. Aimco International Group Corp. reserves the right to make changes to the design without prior notice.



FOUR HOLE TEE PLATE

Part # | A-747

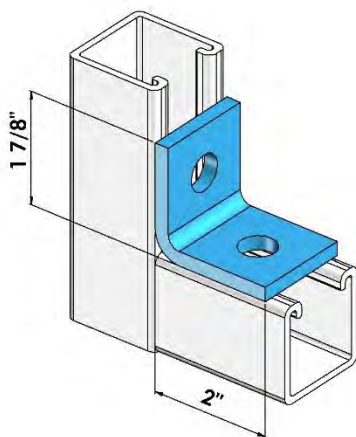
Specification Data	
Hole Dia. (in.)	9/16
Hole Spacing from End (in.)	13/16
Hole Spacing on Center (in.)	1 7/8
Width (in.)	1 5/8
Thickness (in.)	1/4
Approx. Wt. (lbs.)	0.93



FIVE HOLE TEE PLATE

Part # | A-854

Specification Data	
Hole Dia. (in.)	9/16
Hole Spacing from End (in.)	13/16
Hole Spacing on Center (in.)	1 7/8
Width (in.)	1 5/8
Thickness (in.)	1/4
Approx. Wt. (lbs.)	1.35

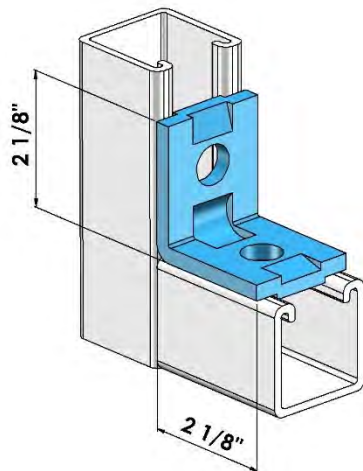


TWO HOLE 90° FITTING

Part # | A-603

Specification Data	
Hole Dia. (in.)	9/16
Hole Spacing from End (in.)	13/16
Hole Spacing on Center (in.)	1 7/8
Width (in.)	1 5/8
Thickness (in.)	1/4
Approx. Wt. (lbs.)	0.37

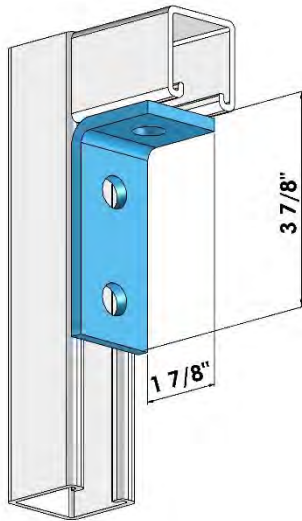
These specifications are for reference only. Aimco International Group Corp. reserves the right to make changes to the design without prior notice.



TWO HOLE 90° FITTING NO TWIST

Part # | A-207A

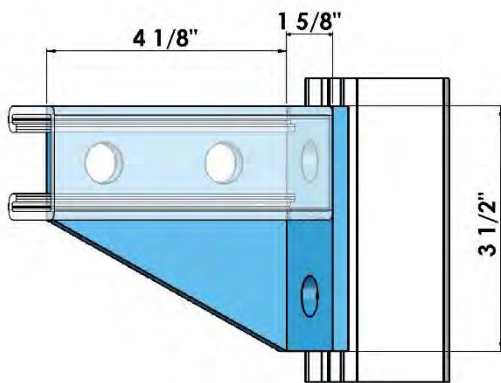
Specification Data	
Hole Dia. (in.)	9/16
Hole Spacing from End (in.)	13/16
Hole Spacing on Center (in.)	1 7/8
Width (in.)	1 5/8
Thickness (in.)	1/4
Approx. Wt. (lbs.)	0.38



THREE HOLE 90° FITTING

Part # | A-210A

Specification Data	
Hole Dia. (in.)	9/16
Hole Spacing from End (in.)	13/16
Hole Spacing on Center (in.)	1 7/8
Width (in.)	1 5/8
Thickness (in.)	1/4
Approx. Wt. (lbs.)	0.51



LEFT FOUR HOLE ANGLE

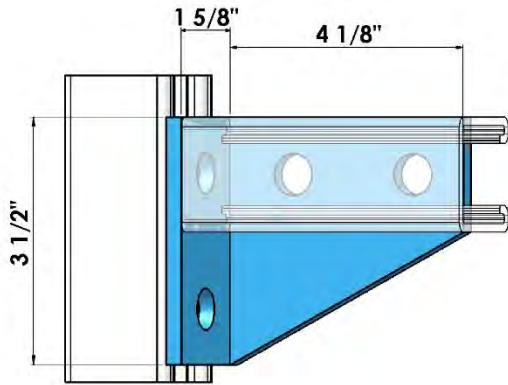
Part # | A-742

Specification Data	
Hole Dia. (in.)	9/16
Hole Spacing from End (in.)	13/16
Hole Spacing on Center (in.)	1 7/8
Width (in.)	1 5/8
Thickness (in.)	1/4
Approx. Wt. (lbs.)	1.00

These specifications are for reference only. Aimco International Group Corp. reserves the right to make changes to the design without prior notice.

RIGHT FOUR HOLE ANGLE

Part # | A-743



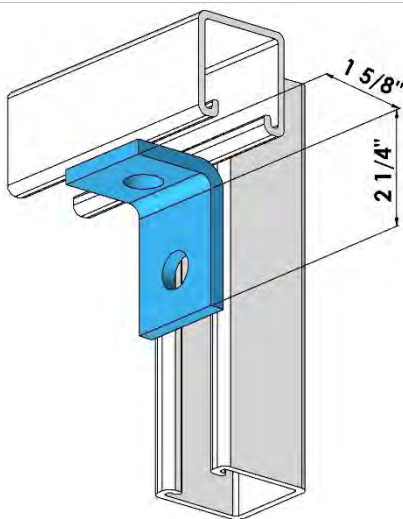
Specification Data

Hole Dia. (in.)	9/16
Hole Spacing from End (in.)	13/16
Hole Spacing on Center (in.)	1 7/8
Width (in.)	1 5/8
Thickness (in.)	1/4
Approx. Wt. (lbs.)	1.00

CROSSING CONNECTIONS

TWO HOLE ANGLE

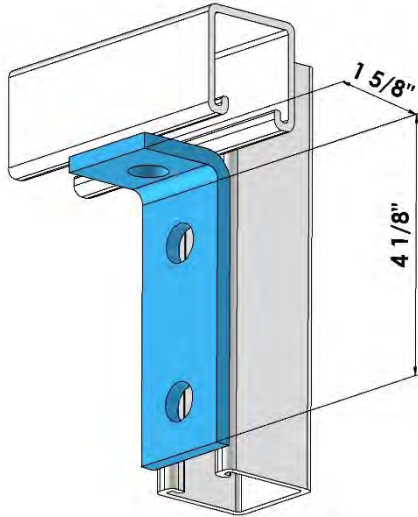
Part # | A-604



Specification Data

Hole Dia. (in.)	9/16
Hole Spacing from End (in.)	13/16
Width (in.)	1 5/8
Thickness (in.)	1/4
Approx. Wt. (lbs.)	0.35

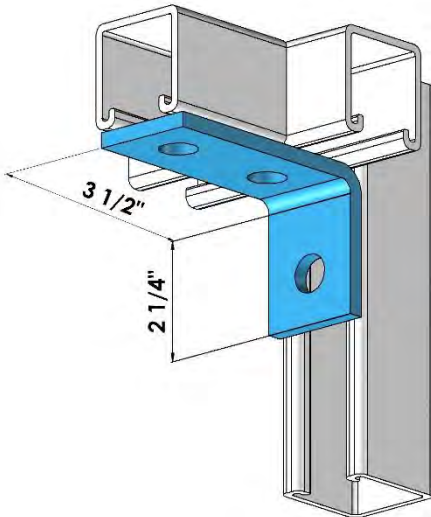
These specifications are for reference only. Aimco International Group Corp. reserves the right to make changes to the design without prior notice.



THREE HOLE ANGLE

Part # | A-606

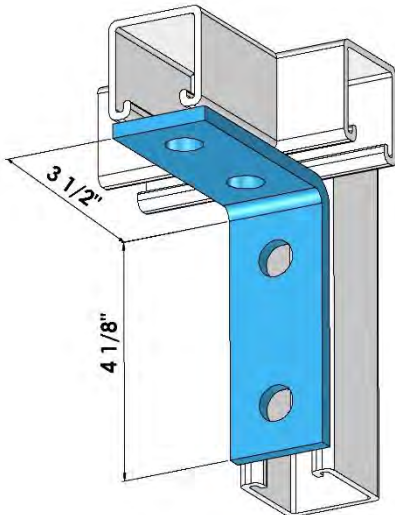
Specification Data	
Hole Dia. (in.)	9/16
Hole Spacing from End (in.)	13/16
Hole Spacing on Center (in.)	1 7/8
Width (in.)	1 5/8
Thickness (in.)	1/4
Approx. Wt. (lbs.)	0.50



THREE HOLE CONNECTOR

Part # | A-605

Specification Data	
Hole Dia. (in.)	9/16
Hole Spacing from End (in.)	13/16
Hole Spacing on Center (in.)	1 7/8
Width (in.)	1 5/8
Thickness (in.)	1/4
Approx. Wt. (lbs.)	0.53



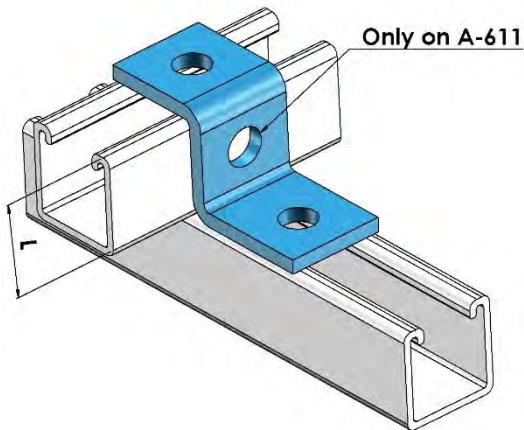
FOUR HOLE ANGLE

Part # | A-607

Specification Data	
Hole Dia. (in.)	9/16
Hole Spacing from End (in.)	13/16
Hole Spacing on Center (in.)	1 7/8
Width (in.)	1 5/8
Thickness (in.)	1/4
Approx. Wt. (lbs.)	0.71

These specifications are for reference only. Aimco International Group Corp. reserves the right to make changes to the design without prior notice.

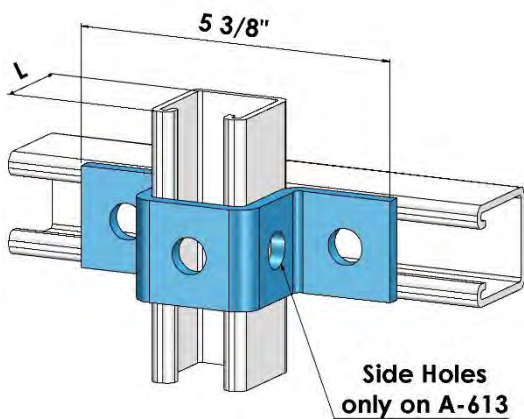
Z SHAPE ANGLE



Part #	L (in.)	Approx. Wt. (lbs.)
A-611	1 5/8	0.53
A-612	1	0.44
A-928	13/16	0.43

Specification Data

Hole Dia. (in.)	9/16
Width (in.)	1 5/8
Thickness (in.)	1/4

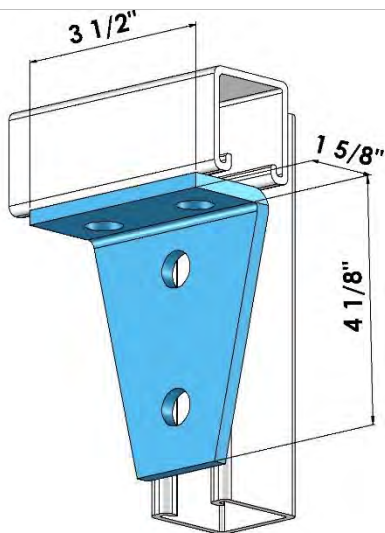


U SHAPE BRACKET

Part #	L (in.)	Approx. Wt. (lbs.)
A-613	1 5/8	0.84
A-614	1	0.75
A-929	13/16	0.70

Specification Data

Hole Dia. (in.)	9/16
Hole Spacing from End (in.)	13/16
Width (in.)	1 5/8
Thickness (in.)	1/4



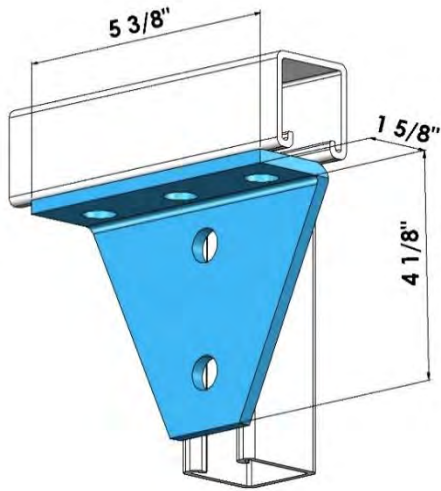
FOUR HOLE ANGLE FITTING

Part # | A-748

Specification Data

Hole Dia. (in.)	9/16
Hole Spacing from End (in.)	13/16
Hole Spacing on Center (in.)	1 7/8
Width (in.)	1 5/8
Thickness (in.)	1/4
Approx. Wt. (lbs.)	0.92

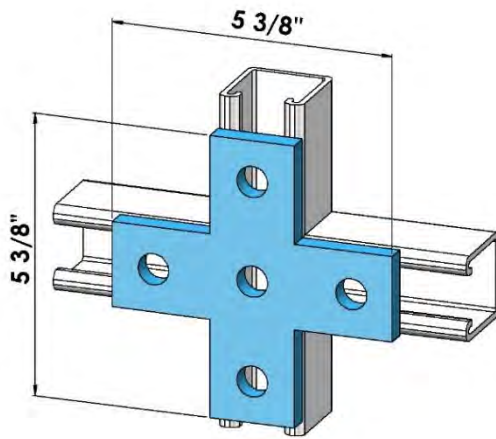
These specifications are for reference only. Aimco International Group Corp. reserves the right to make changes to the design without prior notice.



FIVE HOLE ANGLE FITTING

Part # | A-230A

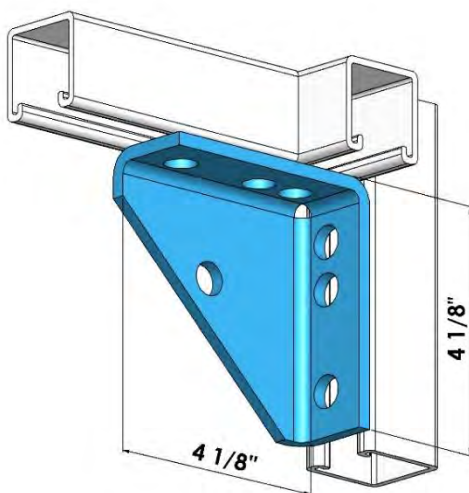
Specification Data	
Hole Dia. (in.)	9/16
Hole Spacing from End (in.)	13/16
Hole Spacing on Center (in.)	1 7/8
Width (in.)	1 5/8
Thickness (in.)	1/4
Approx. Wt. (lbs.)	1.41



FIVE HOLE CROSS PLATE

Part # | A-712

Specification Data	
Hole Dia. (in.)	9/16
Hole Spacing from End (in.)	13/16
Hole Spacing on Center (in.)	1 7/8
Width (in.)	1 5/8
Thickness (in.)	1/4
Approx. Wt. (lbs.)	0.90



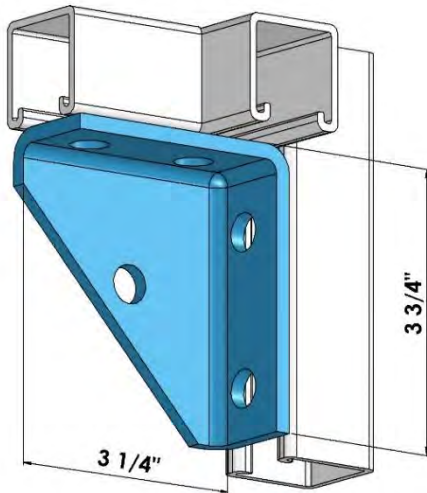
UNIVERSAL SHELF BRACKET

Part # | A-608

Specification Data	
Hole Dia. (in.)	9/16
Hole Spacing from End (in.)	13/16
Width (in.)	1 5/8
Thickness (in.)	1/4
Approx. Wt. (lbs.)	1.34

These specifications are for reference only. Aimco International Group Corp. reserves the right to make changes to the design without prior notice.

FIVE HOLE SHELF BRACKET



Part #

A-216A

Left Hand (Shown)

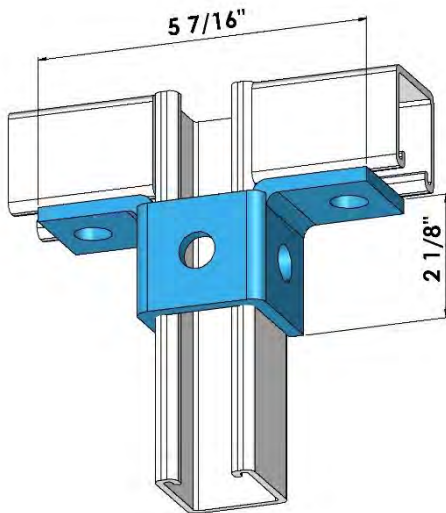
A-215A

Right Hand

Specification Data

Hole Dia. (in.)	9/16
Hole Spacing from End (in.)	13/16
Hole Spacing on Center (in.)	1 7/8
Width (in.)	1 5/8
Thickness (in.)	1/4
Approx. Wt. (lbs.)	1.28

FIVE HOLE WING FITTING



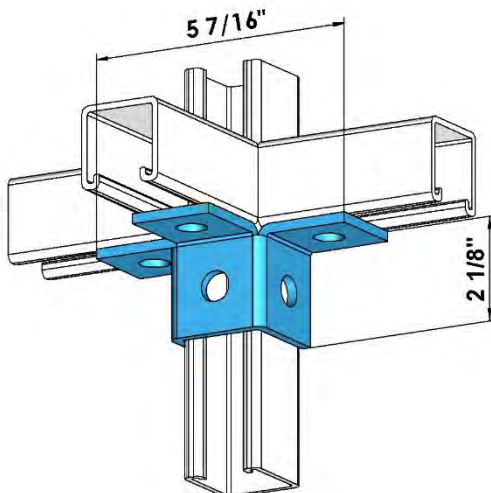
Part #

A-923

Specification Data

Hole Dia. (in.)	9/16
Hole Spacing from End (in.)	13/16
Width (in.)	1 5/8
Thickness (in.)	1/4
Approx. Wt. (lbs.)	0.93

SIX HOLE WING FITTING



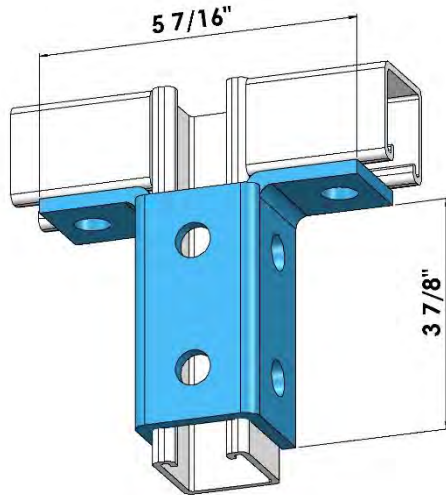
Part #

A-668

Specification Data

Hole Dia. (in.)	9/16
Hole Spacing from End (in.)	13/16
Width (in.)	1 5/8
Thickness (in.)	1/4
Approx. Wt. (lbs.)	1.12

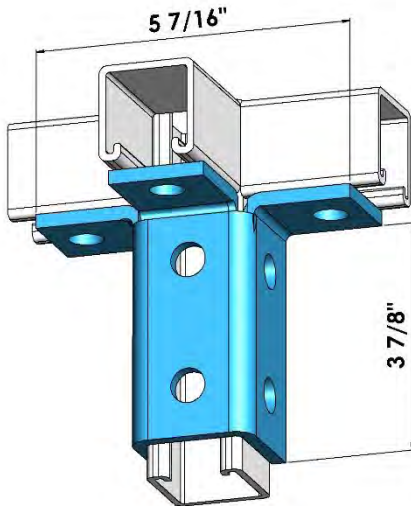
These specifications are for reference only. Aimco International Group Corp. reserves the right to make changes to the design without prior notice.



EIGHT HOLE WING FITTING

Part # | A-821

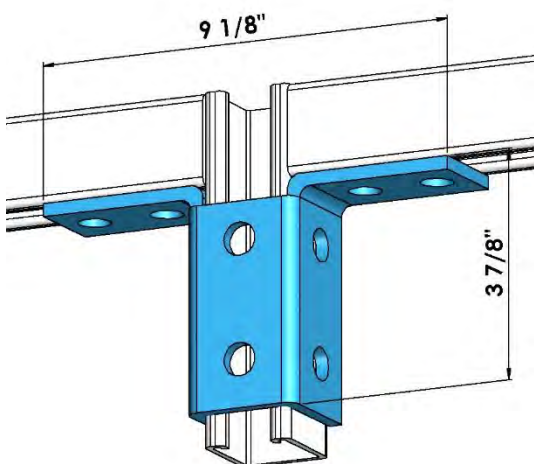
Specification Data	
Hole Dia. (in.)	9/16
Hole Spacing from End (in.)	13/16
Hole Spacing on Center (in.)	1 7/8
Width (in.)	1 5/8
Thickness (in.)	1/4
Approx. Wt. (lbs.)	1.51



NINE HOLE WING FITTING

Part # | A-670

Specification Data	
Hole Dia. (in.)	9/16
Hole Spacing from End (in.)	13/16
Hole Spacing on Center (in.)	1 7/8
Width (in.)	1 5/8
Thickness (in.)	1/4
Approx. Wt. (lbs.)	1.77

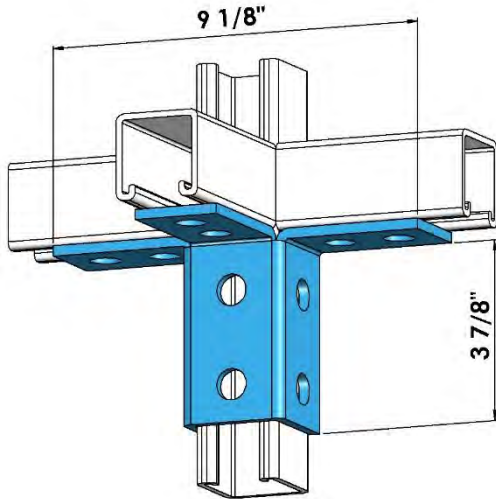


TEN HOLE WING FITTING

Part # | A-913

Specification Data	
Hole Dia. (in.)	9/16
Hole Spacing from End (in.)	13/16
Hole Spacing on Center (in.)	1 7/8
Width (in.)	1 5/8
Thickness I (in.)	1/4
Approx. Wt. (lbs.)	1.93

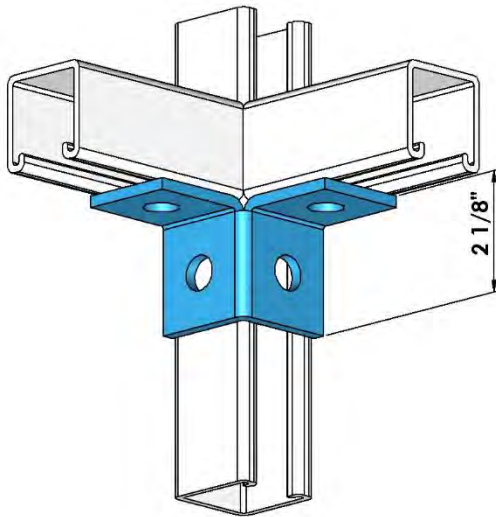
These specifications are for reference only. Aimco International Group Corp. reserves the right to make changes to the design without prior notice.



TWELVE HOLE WING FITTING

Part # | A-669

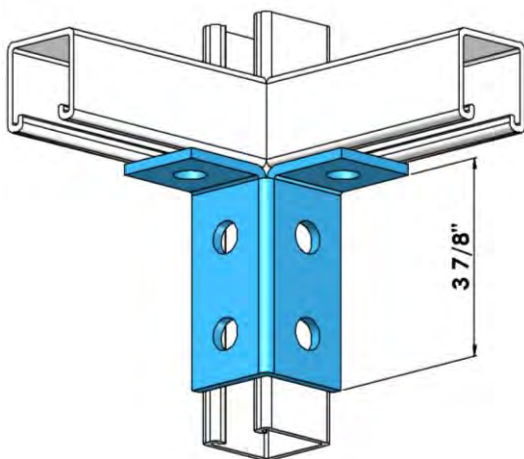
Specification Data	
Hole Dia. (in.)	9/16
Hole Spacing from End (in.)	13/16
Hole Spacing on Center (in.)	1 7/8
Width (in.)	1 5/8
Thickness (in.)	1/4
Approx. Wt. (lbs.)	2.28



FOUR HOLE CORNER FITTING

Part # | A-665

Specification Data	
Hole Dia. (in.)	9/16
Hole Spacing from End (in.)	13/16
Width (in.)	1 5/8
Thickness (in.)	1/4
Approx. Wt. (lbs.)	0.76

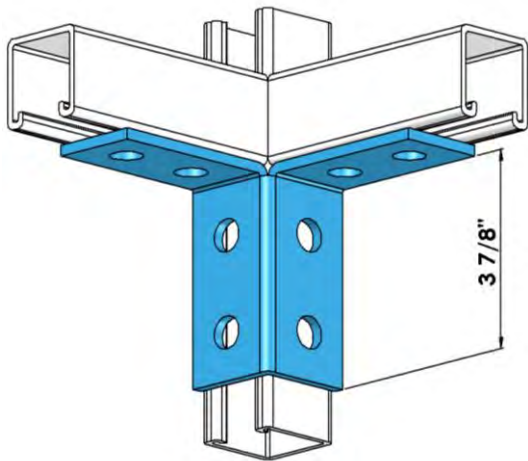


SIX HOLE CORNER FITTING

Part # | A-666

Specification Data	
Hole Dia. (in.)	9/16
Hole Spacing from End (in.)	13/16
Width (in.)	1 5/8
Thickness (in.)	1/4
Approx. Wt. (lbs.)	1.10

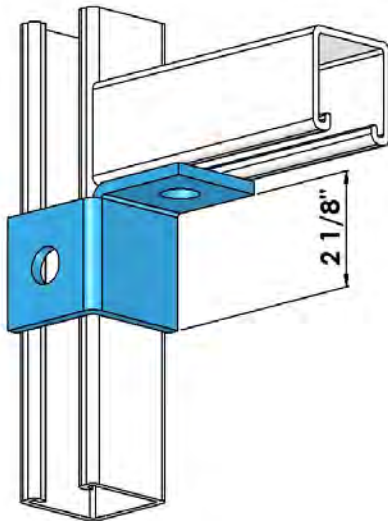
These specifications are for reference only. Aimco International Group Corp. reserves the right to make changes to the design without prior notice.



EIGHT HOLE CORNER FITTING

Part # | A-667

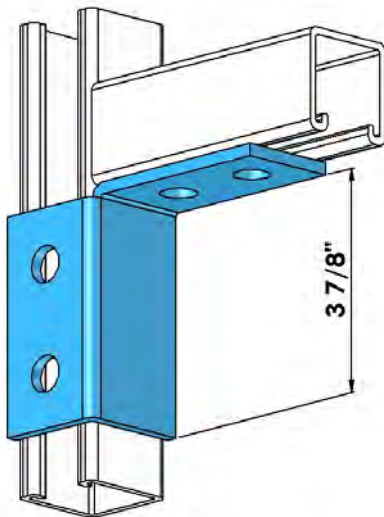
Specification Data	
Hole Dia. (in.)	9/16
Hole Spacing from End (in.)	13/16
Width (in.)	1 5/8
Thickness (in.)	1/4
Approx. Wt. (lbs.)	1.40



TWO HOLE CORNER FITTING

Part # | A-922

Specification Data	
Hole Dia. (in.)	9/16
Hole Spacing from End (in.)	13/16
Width (in.)	1 5/8
Thickness (in.)	1/4
Approx. Wt. (lbs.)	0.60



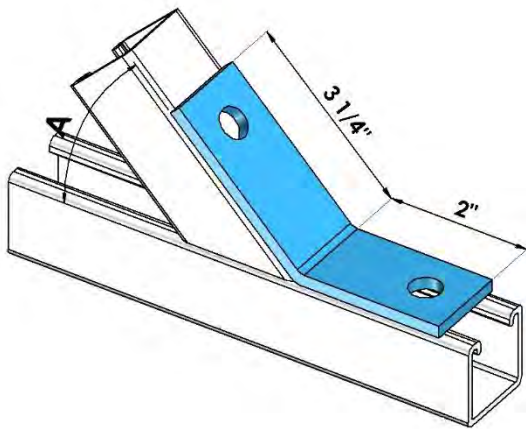
FOUR HOLE CORNER

Part # | A-2128

Specification Data	
Hole Dia. (in.)	9/16
Hole Spacing from End (in.)	13/16
Width (in.)	1 5/8
Thickness (in.)	1/4
Approx. Wt. (lbs.)	1.10

These specifications are for reference only. Aimco International Group Corp. reserves the right to make changes to the design without prior notice.

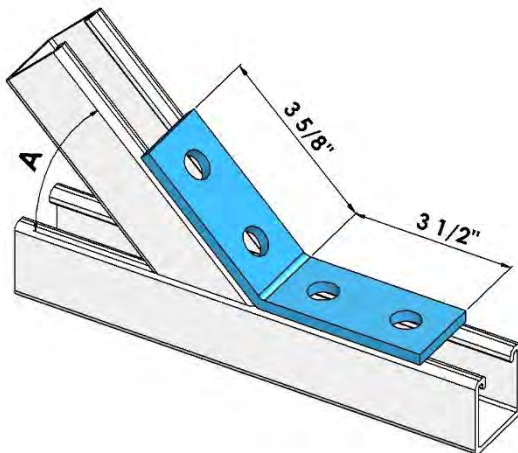
ANGLE CONNECTIONS



TWO HOLE OPEN ANGLE

Part #	A
A-633 30	30°
A-633 45	45°
A-633 60	60°

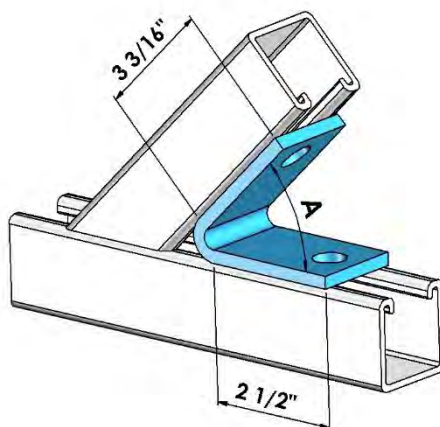
Specification Data	
Hole Dia. (in.)	9/16
Hole Spacing from End (in.)	13/16
Width (in.)	1 5/8
Thickness (in.)	1/4
Approx. Wt. (lbs.)	0.53



FOUR HOLE OPEN ANGLE

Part #	A
A-781 30	30°
A-781 45	45°
A-781 60	60°

Specification Data	
Hole Dia. (in.)	9/16
Hole Spacing from End (in.)	13/16
Hole Spacing on Center (in.)	1 7/8
Width (in.)	1 5/8
Thickness (in.)	1/4
Approx. Wt. (lbs.)	0.70

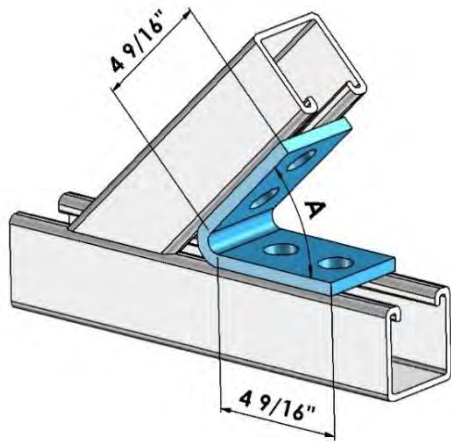


TWO HOLE CLOSED ANGLE

Part #	A
A-624 30	30°
A-624 45	45°
A-624 60	60°

Specification Data	
Hole Dia. (in.)	9/16
Hole Spacing from End (in.)	13/16
Width (in.)	1 5/8
Thickness (in.)	1/4
Approx. Wt. (lbs.)	0.53

These specifications are for reference only. Aimco International Group Corp. reserves the right to make changes to the design without prior notice.

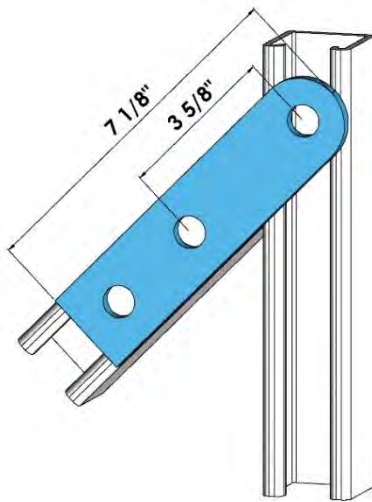


FOUR HOLE CLOSED ANGLE

Part #	A
A-793 30	30°
A-793 45	45°
A-793 60	60°

Specification Data

Hole Dia. (in.)	9/16
Hole Spacing from End (in.)	13/16
Hole Spacing on Center (in.)	1 7/8
Width (in.)	1 5/8
Thickness (in.)	1/4
Approx. Wt. (lbs.)	0.96



THREE HOLE ADJUSTABLE PLATE

Part # | A-117P

Specification Data

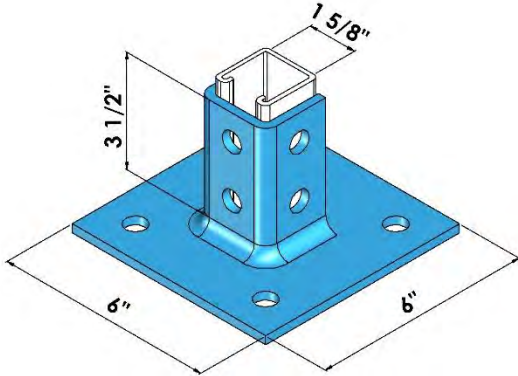
Hole Dia. (in.)	9/16
Hole Spacing from End (in.)	13/16
Width (in.)	1 5/8
Thickness (in.)	1/4
Approx. Wt. (lbs.)	0.75

These specifications are for reference only. Aimco International Group Corp. reserves the right to make changes to the design without prior notice.

POST BASES

SINGLE POST BASE

Part # | A-3033

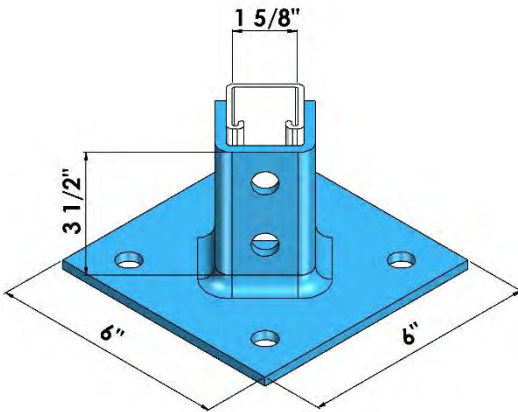


Specification Data

Hole Dia. (in.)	9/16
Hole Spacing from End (in.)	13/16
Hole Spacing on Center (in.)	1 7/8
Width (in.)	1 5/8
Thickness (in.)	1/4
Approx. Wt. (lbs.)	3.43

OFFSET SINGLE POST BASE

Part # | A-30330

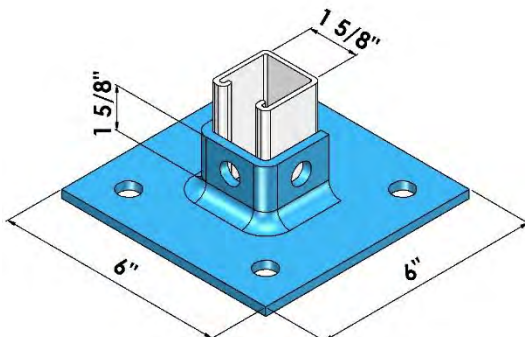


Specification Data

Hole Dia. (in.)	9/16
Hole Spacing from End (in.)	13/16
Hole Spacing on Center (in.)	1 7/8
Width (in.)	1 5/8
Thickness (in.)	1/4
Approx. Wt. (lbs.)	3.43

SINGLE POST BASE SHORT

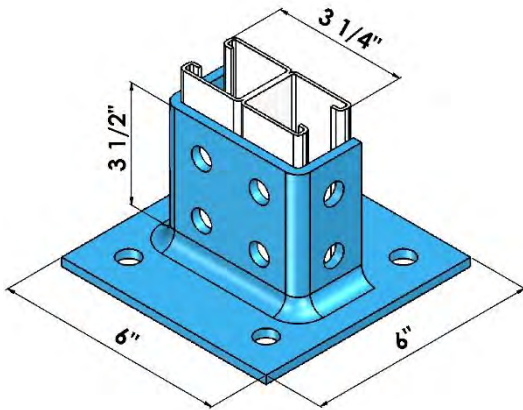
Part # | A-503PB



Specification Data

Hole Dia. (in.)	9/16
Hole Spacing from End (in.)	13/16
Width (in.)	1 5/8
Thickness (in.)	1/4
Approx. Wt. (lbs.)	3.10

These specifications are for reference only. Aimco International Group Corp. reserves the right to make changes to the design without prior notice.

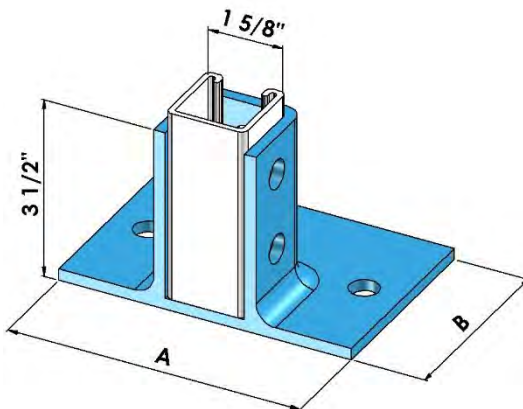


DOUBLE POST BASE

Part # | A-3064

Specification Data

Hole Dia. (in.)	9/16
Hole Spacing from End (in.)	13/16
Hole Spacing on Center (in.)	1 7/8
Width (in.)	1 5/8
Thickness (in.)	1/4
Approx. Wt. (lbs.)	3.91

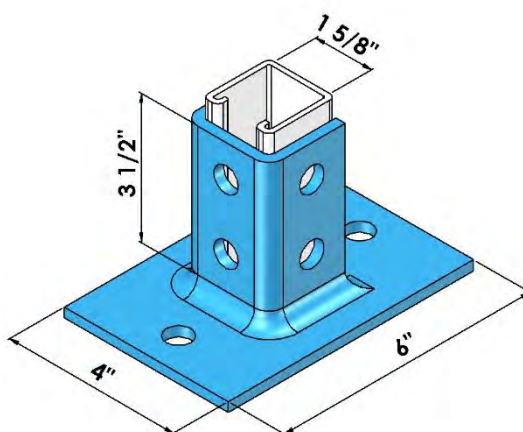


SINGLE POST BASE OPEN

Part #	A (in.)	B (in.)	Approx. Wt. (lbs.)
A-508PB	6	4	3.00
A-PB200	8	3	3.10

Specification Data

Hole Dia. (in.)	9/16
Hole Spacing from End (in.)	13/16
Hole Spacing on Center (in.)	1 7/8
Width (in.)	1 5/8
Thickness (in.)	1/4



SINGLE POST BASE NARROW

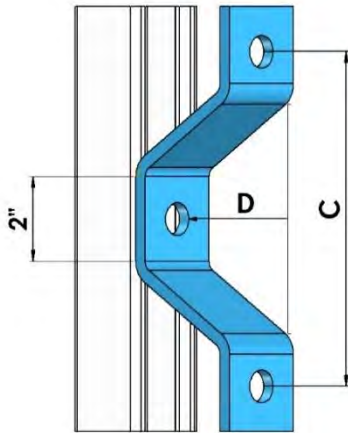
Part # | A-509PB

Specification Data

Hole Dia. (in.)	9/16
Hole Spacing from End (in.)	13/16
Hole Spacing on Center (in.)	1 7/8
Width (in.)	1 5/8
Thickness (in.)	1/4
Approx. Wt. (lbs.)	3.00

These specifications are for reference only. Aimco International Group Corp. reserves the right to make changes to the design without prior notice.

OFFSET CONNECTIONS

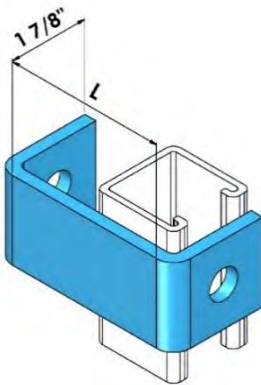


WALL LADDER BRACKET

Part #	D (in.)	C (in.)	Approx. Wt. (lbs.)
A-1204	2 3/8	6	1.10
A-1205	4 3/8	8	1.64
A-1206	6 3/8	10	2.00
A-1207	8 3/8	12	2.53
A-1208	10 3/8	14	3.18

Specification Data

Hole Dia. (in.)	9/16
Hole Spacing from End (in.)	13/16
Width (in.)	1 5/8
Thickness (in.)	1/4

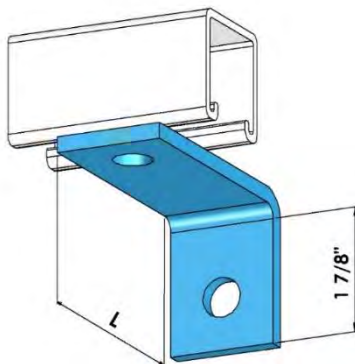


CLEVIS CONNECTOR

Part #	L (in.)	Approx. Wt. (lbs.)
A-402U	4	0.78
A-403U	5	0.89
A-404U	6	1.07
A-405U	7	1.12
A-406U	8	1.24

Specification Data

Hole Dia. (in.)	9/16
Hole Spacing from End (in.)	13/16
Width (in.)	1 5/8
Thickness l (in.)	1/4



OFFSET CONNECTOR

Part #	L (in.)	Approx. Wt. (lbs.)
A-208 3A	3	0.48
A-208 35A	3 1/2	0.53
A-208 4A	4	0.60

Specification Data

Hole Dia. (in.)	9/16
Hole Spacing from End (in.)	13/16
Width (in.)	1 5/8
Thickness (in.)	1/4

These specifications are for reference only. Aimco International Group Corp. reserves the right to make changes to the design without prior notice.

Section 6: Beam Clamps

FUNCTIONS AND FEATURES

Beam Clamps are designed to secure all 1 5/8" wide channels or threaded rods, to beams or supports for the purpose of running pipes and conduits. Where indicated, Beam Clamps must be used in pairs mounted in opposite directions. For Beam Clamps with Hot-Dip Galvanized finish, standard hardware is in Zinc Electro-Galvanized finish.

MATERIALS

Carbon Steel (ASTM A1011)

Stainless Steel - Type 304 or 316 (ASTM A240)

Malleable Cast Iron

FINISHES

Hot-Dip Galvanized (ASTM A123)

Zinc Electro-Galvanized (ASTM B633)

SETSCREW TORQUE

Conforms to ASTM A307. Unless otherwise noted, recommended torque for the setscrew are as follows:

Setscrew Size	1/4"-20	3/8"-16	1/2"-13	5/8"-11	3/4"-10
Torque (ft.-lbs.)	4	5	11	21	34

STAINLESS STEEL OPTIONS

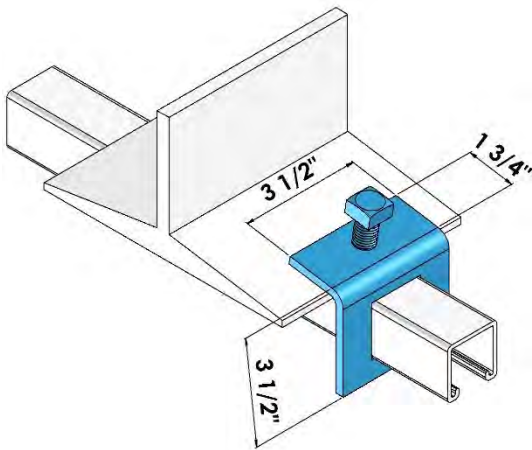
All Beam Clamps are available in 304 Stainless Steel or 316 Stainless Steel (ASTM A240)

NOTE

The more popular Beam Clamps are illustrated on the following pages. However, there are many other types of Beam Clamps available, please refer to our Pipe Hangers & Supports catalogue for more details.

WINDOW BEAM CLAMP

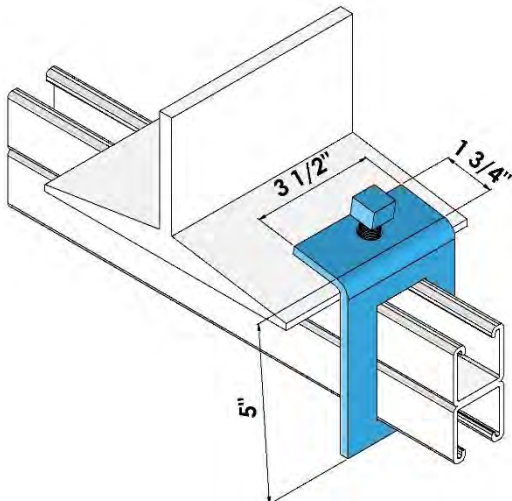
Part # | A-855



Specification Data	
Thickness (in.)	1/4
Setscrew included (in.)	1/2
Max. Rec. Load Each (lbs.)	500
Max. Flange Thickness (in.)	7/8
Approx. Wt. (lbs.)	1.05
Note	Must be used in pairs

WINDOW BEAM CLAMP DEEP

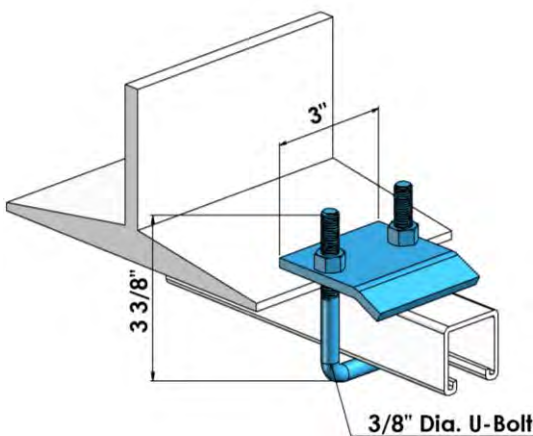
Part # | A-855D



Specification Data	
Thickness (in.)	1/4
Setscrew included (in.)	1/2
Max. Rec. Load Each (lbs.)	500
Max. Flange Thickness (in.)	7/8
Approx. Wt. (lbs.)	1.21
Note	Must be used in pairs

U-BOLT BEAM CLAMP

Part # | A-2652

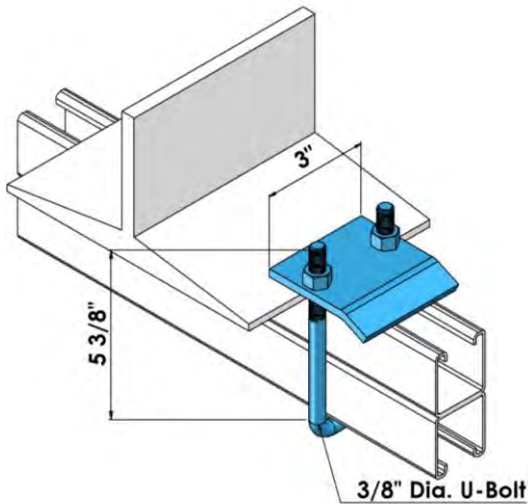


Specification Data	
Thickness (in.)	1/4
Max. Rec. Load Each (lbs.)	1200
Max. Flange Thickness (in.)	3/4
Approx. Wt. (lbs.)	0.77
Note	Must be used in pairs

These specifications are for reference only. Aimco International Group Corp. reserves the right to make changes to the design without prior notice.

U-BOLT BEAM CLAMP DEEP

Part # | A-2651

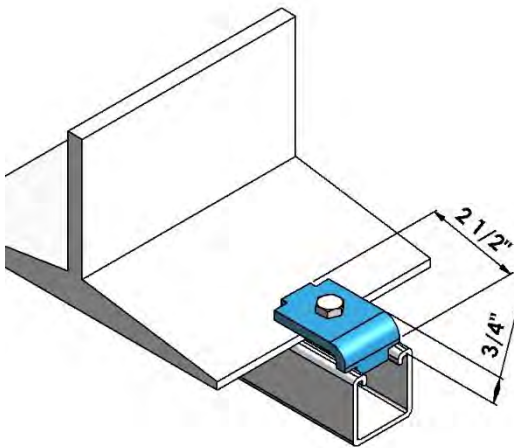


Specification Data

Thickness (in.)	1/4
Max. Rec. Load Each (lbs.)	1200
Max. Flange Thickness (in.)	3/4
Approx. Wt. (lbs.)	0.78
Note	Must be used in pairs

FLANGE STRUT BEAM CLAMP

Part # | A-686

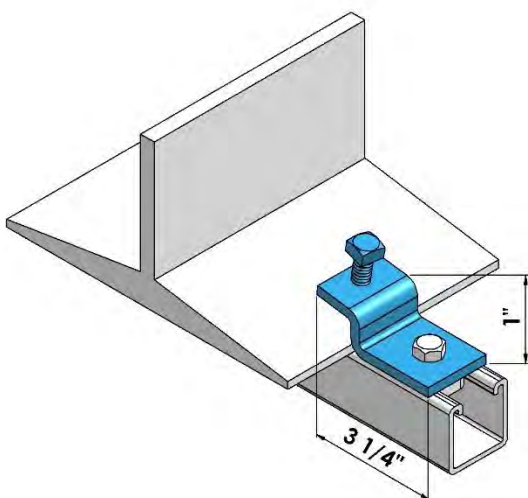


Specification Data

Thickness (in.)	1/4
Max. Rec. Load Each (lbs.)	
12 Gauge Channel	600
14 Gauge Channel	500
16 Gauge Channel	450
Max. Flange Thickness (in.)	1/2
Hole Dia. for Attachment (in.)	9/16
Approx. Wt. (lbs.)	0.28
Note	Must be used in pairs

Z SHAPE BEAM CLAMP

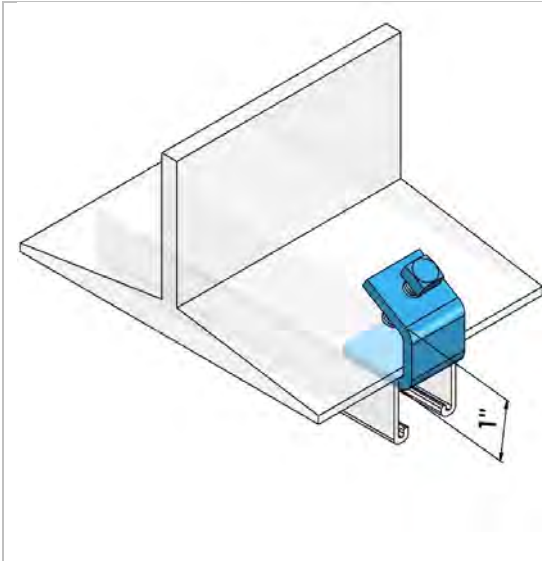
Part # | A-685



Specification Data

Thickness (in.)	3/8
Setscrew included (in.)	1/2
Max. Rec. Load Each (lbs.)	
12 Gauge Channel	600
14 Gauge Channel	500
16 Gauge Channel	450
Max. Flange Thickness (in.)	1
Hole Dia. for Attachment (in.)	9/16
Approx. Wt. (lbs.)	0.53
Note	Must be used in pairs

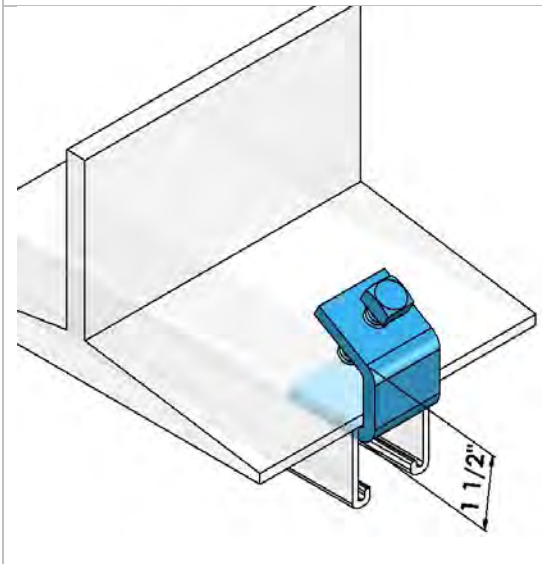
These specifications are for reference only. Aimco International Group Corp. reserves the right to make changes to the design without prior notice.



STRUT BEAM CLAMP 1" OPENING

Part # | A-907A

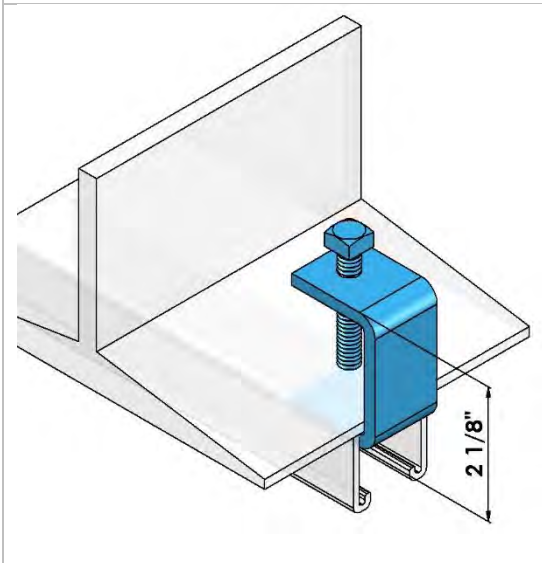
Specification Data	
Thickness (in.)	1/4
Setscrew included (in.)	3/8
Max. Rec. Load Each (lbs.)	450
Max. Flange Thickness (in.)	3/4
Approx. Wt. (lbs.)	0.35
Note	Must be used in pairs



STRUT BEAM CLAMP 1 1/2" OPENING

Part # | A-907B

Specification Data	
Thickness (in.)	3/8
Setscrew included (in.)	1/2
Max. Rec. Load Each (lbs.)	1000
Max. Flange Thickness (in.)	1 1/4
Approx. Wt. (lbs.)	0.72
Note	Must be used in pairs

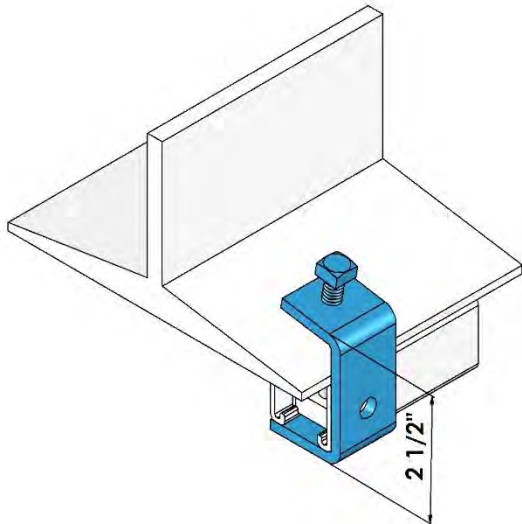


STRUT BEAM CLAMP 2 1/8" OPENING

Part # | A-907C

Specification Data	
Thickness (in.)	3/8
Setscrew included (in.)	1/2
Max. Rec. Load Each (lbs.)	900
Max. Flange Thickness (in.)	2
Approx. Wt. (lbs.)	0.78
Note	Must be used in pairs

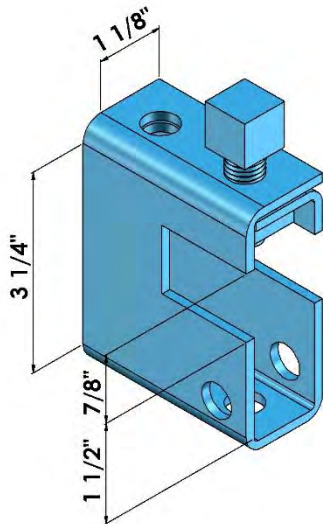
These specifications are for reference only. Aimco International Group Corp. reserves the right to make changes to the design without prior notice.



STRUT BEAM CLAMP 2 1/2" OPENING

Part # | A-684

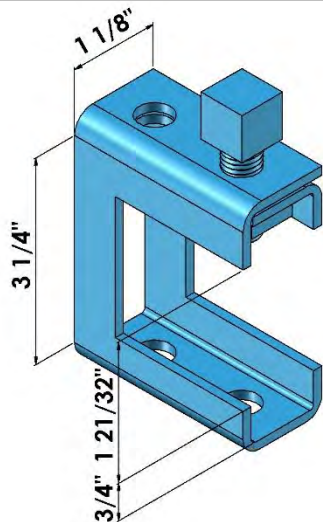
Specification Data	
Thickness (in.)	3/8
Setscrew included (in.)	1/2
Max. Rec. Load Each (lbs.)	500
Max. Flange Thickness (in.)	7/8
Hole Dia. for Attachment (in.)	9/16
Approx. Wt. (lbs.)	0.89
Note	Must be used in pairs



STRUT BEAM CLAMP 7/8" OPENING

Part # | A-2622HD 7/8

Specification Data	
Setscrew included (in.)	1/2
Max. Rec. Load Each (lbs.)	500
Max. Flange Thickness (in.)	7/8
Hole Dia. for Attachment (in.)	9/16
Approx. Wt. (lbs.)	0.74



STRUT BEAM CLAMP 1 21/32" OPENING

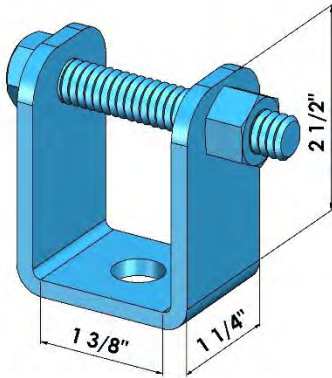
Part # | A-2622HD 1 21/32

Specification Data	
Setscrew included (in.)	1/2
Max. Rec. Load Each (lbs.)	400
Max. Flange Thickness (in.)	5/8
Hole Dia. for Attachment (in.)	9/16
Approx. Wt. (lbs.)	0.65

These specifications are for reference only. Aimco International Group Corp. reserves the right to make changes to the design without prior notice.

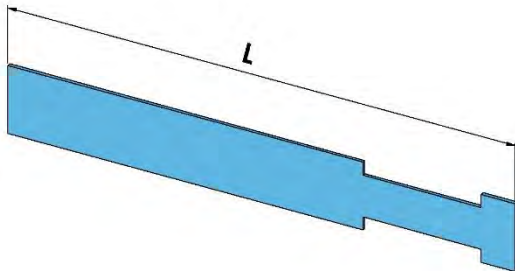
STRUT CLEVIS HANGER

Part # | A-2623



Specification Data	
Hole Dia. for Attachment (in.)	9/16
Max. Rec. Load Each (lbs.)	500
Approx. Wt. (lbs.)	0.25
Note	Used in conjunction with Strut Beam Clamp 7/8" Opening

SAFETY STRAP

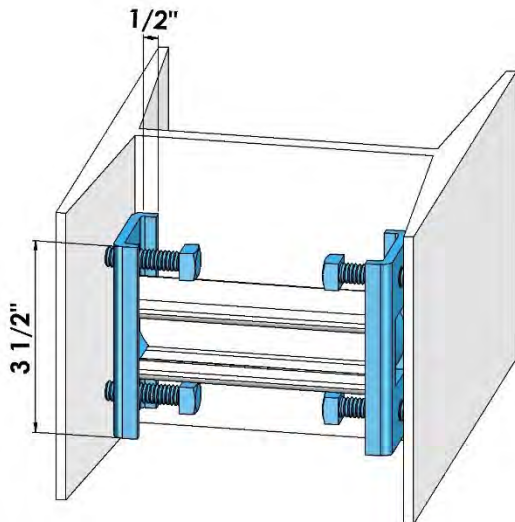


Part #	L (in.)	Beam Flange Range (in.)	Max. Flange Thickness (in.)	Approx. Wt. (lbs.)
A-2622 9	9	6	3/4	0.20
A-2622 12	12	9	3/4	0.28
A-2622 15	15	12	3/4	0.38
A-2622 20	20	16	3/4	0.47

Note: Used in conjunction with Strut Beam Clamp 1 21/32" Opening and 7/8" Opening

COLUMN INSERT

Part # | A-954BC



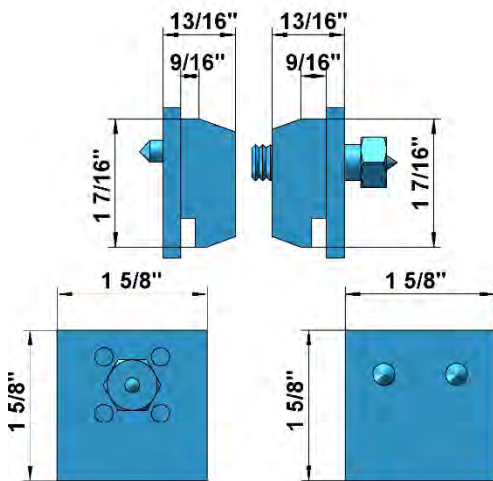
Column Insert used with	Pull-Out Resistance (lbs.)	Slip Resistance (lbs.)
1 5/8" x 1 5/8" x 12Ga Strut Channel	1000	800
1 5/8" x 1 5/8" x 14Ga Strut Channel	700	500
1 5/8" x 1 5/8" x 16Ga Strut Channel	500	300

Note: Used between column flanges. No welding required. The length of strut channel is the inside beam width less 1". Must be used in pairs. Approx. Wt. Per Pair is 1.04lbs.

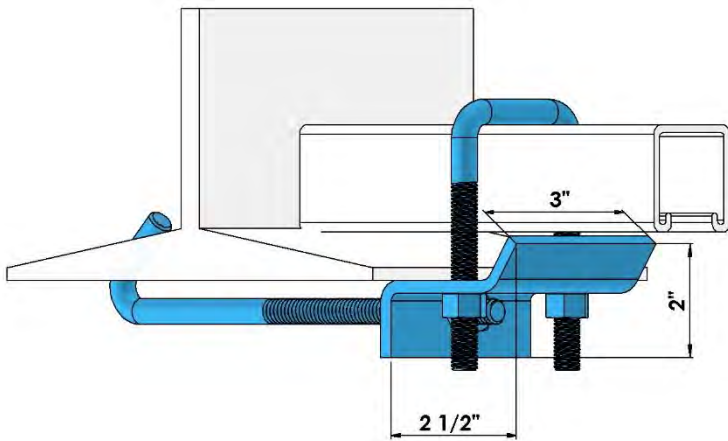
These specifications are for reference only. Aimco International Group Corp. reserves the right to make changes to the design without prior notice.

COLUMN INSERT SQUARE

Part # | A-CAD BC23



Specification Data	
Static Load (lbs.)	800
Approx. Wt. Per Pair (lbs.)	0.55
Note	Complete with pointed head hex bolts for easy installation. Must be used in pairs.

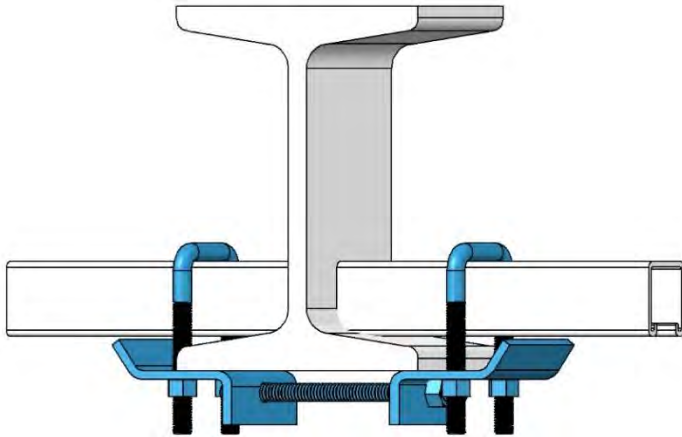


J-HOOK BEAM CLAMP

Part #	3/8" J-Hook Length (in.)	3/8" U-Bolt Length (in.)	Thickness (in.)	Max. Flange Thickness (in.)	Approx. Wt. (lbs.)
A-948SBC 6	6	3 3/4	1/4	7/8	1.08
A-948SBC 8	8	3 3/4	1/4	7/8	1.19
A-948SBC 14	14	3 3/4	1/4	7/8	1.30
A-948LBC 6	6	5 3/8	1/4	7/8	1.16
A-948LBC 8	8	5 3/8	1/4	7/8	1.27
A-948LBC 14	14	5 3/8	1/4	7/8	1.38

Recommended Torque: J-Hook Nut (60 in.-lbs.), U-Bolt Nut(150 in.-lbs)

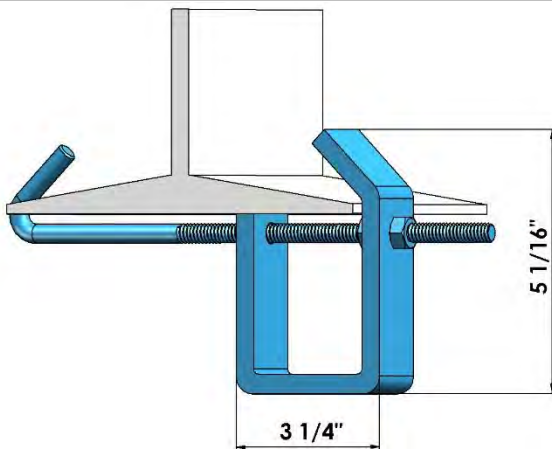
These specifications are for reference only. Aimco International Group Corp. reserves the right to make changes to the design without prior notice.



**J-HOOK BEAM CLAMP
DOUBLE**

Part #	3/8" J-Hook Length (in.)	3/8" U-Bolt Length (in.)	Thickness (in.)	Max. Flange Thickness (in.)
A-949SBC 6	6	3 3/4	1/4	7/8
A-949SBC 8	8	3 3/4	1/4	7/8
A-949SBC 14	12	3 3/4	1/4	7/8
A-949LBC 6	6	5 3/8	1/4	7/8
A-949LBC 8	8	5 3/8	1/4	7/8
A-949LBC 14	12	5 3/8	1/4	7/8

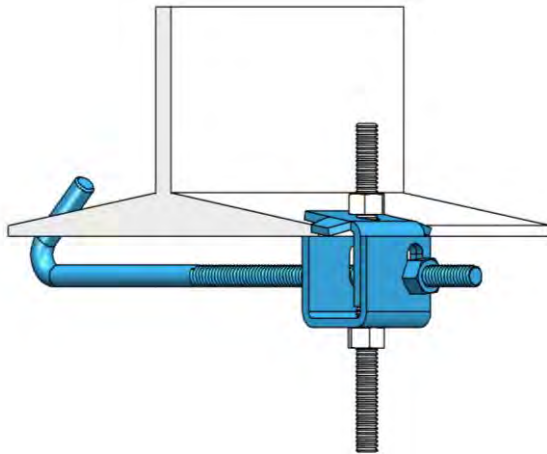
Recommended Torque: J-Hook Nut (60 in.-lbs.), U-Bolt Nut(150 in.-lbs)



**J-HOOK BEAM CLAMP
HEAVY DUTY**

Part #	J-Hook Length (in.)	Beam Flange Range (in.)	Thickness (in.)	Max. Rec. Load (lbs.)
A-997BC	11	4 - 9	3/8	800
A-999BC	19 1/2	7 - 17	3/8	800

These specifications are for reference only. Aimco International Group Corp. reserves the right to make changes to the design without prior notice.



**J-HOOK BEAM CLAMP
LIGHT DUTY**

Part #	Beam Flange Range (in.)	Thickness (in.)	Max. Rec. Load (lbs.)
A-984-126	2 1/2 - 6	3/16	500
A-094-129	5 1/2 - 9	3/16	500
A-084-1212	8 1/2 - 12	3/16	500

These specifications are for reference only. Aimco International Group Corp. reserves the right to make changes to the design without prior notice.

Section 7: Brackets

FUNCTIONS AND FEATURES

Brackets are designed to provide support as a cantilever from the wall. They can also be used in conjunction with electrical fittings.

MATERIALS

Hot-Rolled Steel (ASTM A1011/A1018)

Stainless Steel - Type 304 or 316 (ASTM A240)

FINISHES

Hot-Dip Galvanized (ASTM A123/A153)

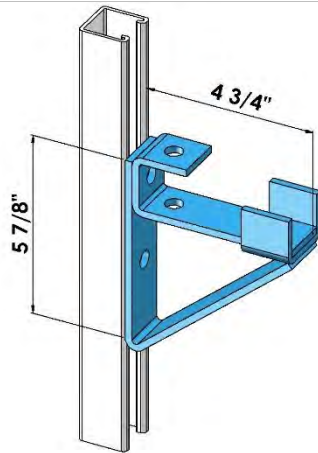
Zinc Electro-Galvanized (ASTM B633)

STAINLESS STEEL OPTIONS

All Brackets are available in 304 Stainless Steel or 316 Stainless Steel (ASTM A240)

NOTE

The more popular Brackets are illustrated on the following pages. However, there are other brackets available. Please contact us for any other brackets you may need for specific applications.

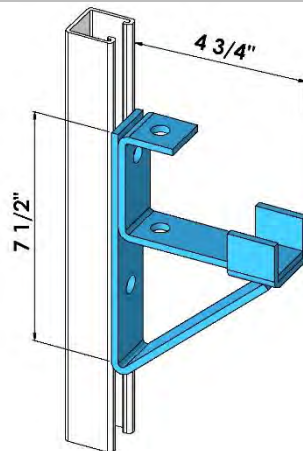


BRACKET FOR SINGLE CHANNEL

Part # | A-708

Specification Data

Thickness (in.)	1/4
Holes Dia. (in.)	9/16
Uniform Design Load (in.-lbs.)	6300
Safety Factor	2.5
Approx. Wt. (lbs.)	2.10
Note	Load is in "in.-lbs." and applies to fitting only, not strength of the strut arm. Load rating is based on use with 12 gauge strut. If 14 gauge strut is used, load is reduced to 4400 in.-lbs.



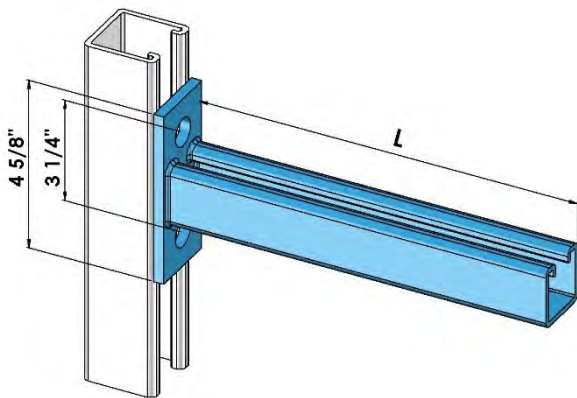
BRACKET FOR DOUBLE CHANNEL

Part # | A-709

Specification Data

Thickness (in.)	1/4
Holes Dia. (in.)	9/16
Uniform Design Load (in.-lbs.)	13000
Safety Factor	2.5
Approx. Wt. (lbs.)	2.55
Note	Load is in "in.-lbs." and applies to fitting only, not strength of the strut arm. Load rating is based on use with 12 gauge strut. If 14 gauge strut is used, load is reduced to 9100 in.-lbs.

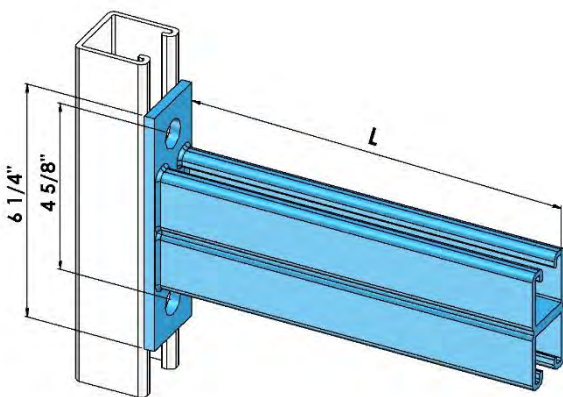
These specifications are for reference only. Aimco International Group Corp. reserves the right to make changes to the design without prior notice.



SINGLE CHANNEL SUPPORT BRACKET

Part #	L (in.)	Uniform Design Load (lbs.)
A-651 6	6	1400
A-651 8	8	1100
A-651 12	12	750
A-651 14	14	600
A-651 18	18	500
A-651 24	24	455

Specification Data	
Holes Dia. (in.)	9/16
Hole Spacing from End (in.)	13/16
Safety Factor	2.5
Note	The uniform design load is based on use with 12 gauge strut channel.

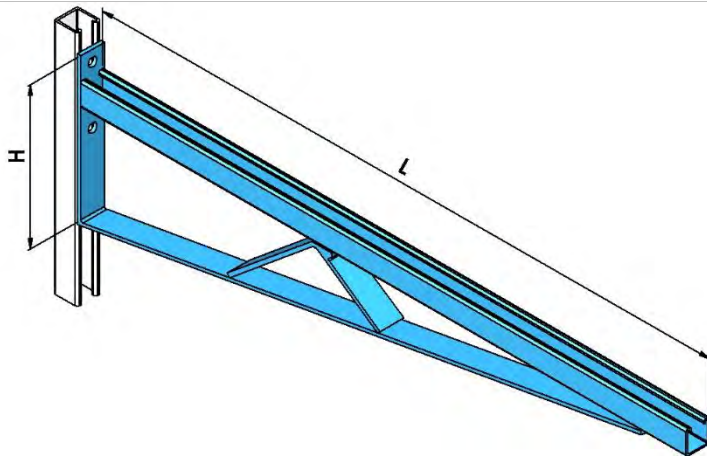


DOUBLE CHANNEL SUPPORT BRACKET

Part #	L (in.)	Uniform Design Load (lbs.)
A-809 6	6	2150
A-809 8	8	2000
A-809 12	12	1900
A-809 14	14	1500
A-809 18	18	1200
A-809 24	24	930
A-809 30	30	780
A-809 36	36	610

Specification Data	
Holes Dia. (in.)	9/16
Hole Spacing from End (in.)	13/16
Safety Factor	2.5
Note	The uniform design load is based on use with 12 gauge strut channel.

These specifications are for reference only. Aimco International Group Corp. reserves the right to make changes to the design without prior notice.

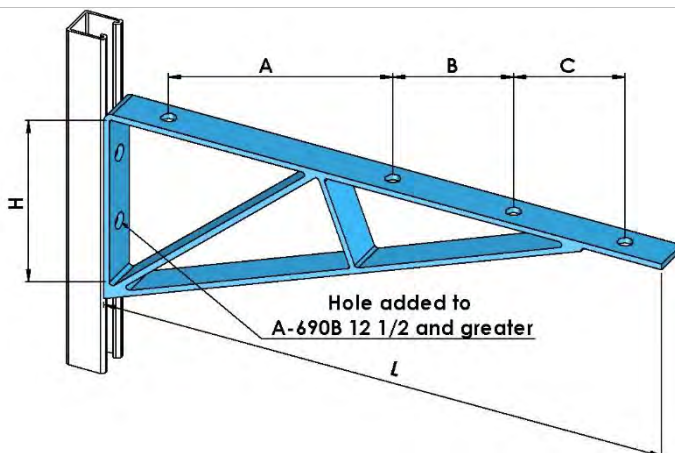


CANTILEVER STRUT BRACKET

Specification Data

Holes Dia. (in.)	9/16
Hole Spacing from End (in.)	13/16
Safety Factor	2.5
Note	Support added to A-3282 26 1/2 and greater. The uniform design load is based on use with 12 gauge strut channel

Part #	L (in.)	H (in.)	Uniform Design Load (lbs.)
A-3282 8 1/2	8 1/2	8 3/4	2000
A-3282 14 1/2	14 1/2	8 3/4	2000
A-3282 20 1/2	20 1/2	8 7/8	1200
A-3282 26 1/2	26 1/2	8 7/8	975
A-3282 32 1/2	32 1/2	11 1/4	920
A-3282 38 1/2	38 1/2	11 1/2	860



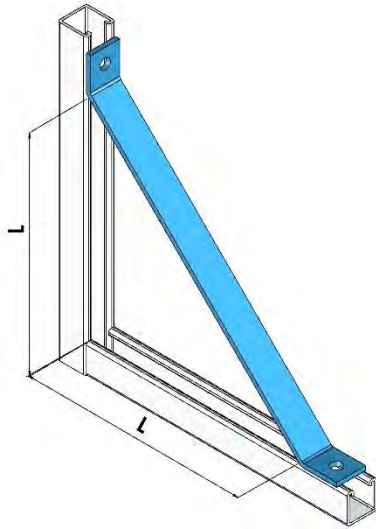
SHELF BRACKET

Specification Data

Thickness (in.)	1/4
Holes Dia. (in.)	9/16
Safety Factor	2.5
Note	The uniform design load is based on use with 12 gauge strut channel. Support added to A-690B 16 1/2 and greater

Part #	L (in.)	H (in.)	A (in.)	B (in.)	C (in.)	Uniform Design Load (lbs.)
A-690B 8 1/2	8 1/2	4	-	-	-	820
A-690B 10 1/2	10 1/2	4	4 1/4	-	3 3/4	820
A-690B 12 1/2	12 1/2	6	3 1/4	3	3 3/4	950
A-690B 14 1/2	14 1/2	6	3 1/4	3	5 3/4	950
A-690B 16 1/2	16 1/2	6	5	3 1/4	5 3/4	1150
A-690B 18 1/2	18 1/2	6	5 1/4	3	7 3/4	1090
A-690B 20 1/2	20 1/2	6	7 1/8	3 1/8	7 3/4	670

These specifications are for reference only. Aimco International Group Corp. reserves the right to make changes to the design without prior notice.



KNEE BRACE

Part #	L (in.)	Approx. Wt. (lbs.)
A-926 12	12	2.10
A-926 18	18	2.90
A-926 24	24	4.07

Specification Data

Hole Dia. (in.)	9/16
Hole Spacing from End (in.)	13/16
Width (in.)	1 5/8
Thickness (in.)	1/4

These specifications are for reference only. Aimco International Group Corp. reserves the right to make changes to the design without prior notice.

Section 8: Electrical & Raceway Fittings

FUNCTIONS AND FEATURES

Electrical and Raceway Fittings conform with the Article 384 of the National Electrical Code, NFPA 70. The products in this category are designed to eliminate the individual suspension of fluorescent lighting fixtures, which saves installations labour and materials.

The metal framing system requires no welding, drilling, or other complex fabrication techniques, this means quicker, easier solutions for virtually any electrical support application. Thus, the Strut Products together with Electrical and Raceway Fittings are part of an integrated system that can be used for raceways, trapeze hangers, cable tray supports, lighting grids, fluorescent-fixture supports, and many other electrical applications.

Raceways with external joiners shall use a 40% wire fill calculation to determine the number of conductors permitted. Raceways with internal joiners shall use a 25% wire fill calculation to determine the number of conductors permitted.

MATERIALS

Carbon Steel (ASTM A1011)

Stainless Steel - Type 304 or 316 (ASTM A240)

FINISHES

Hot-Dip Galvanized (ASTM A123/A153)

Zinc Electro-Galvanized (ASTM B633)

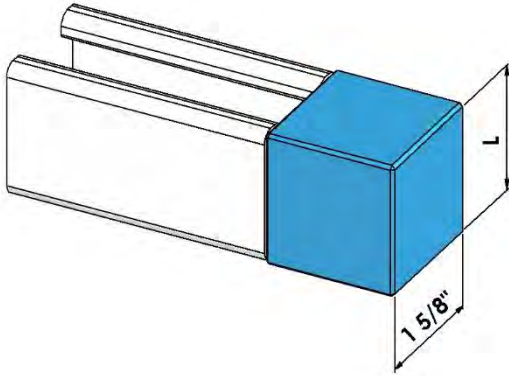
STAINLESS STEEL OPTIONS

Some of the Electrical and Raceway Fittings are available in 304 Stainless Steel or 316 Stainless Steel (ASTM A240)

NOTE

The more popular Electrical and Raceway Fittings are illustrated on the following pages. However, there are many other electrical and raceway products available. Please contact us for any other products you may need.

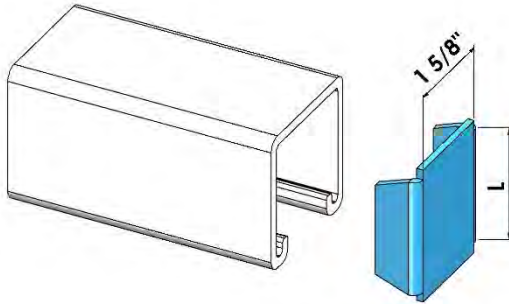
SAFETY END CAP PVC



Part #	L (in.)	Approx. Wt (lbs.)
A-655P 1 5/8	1 5/8	0.04
A-655P 1	1	0.03
A-655P 13/16	13/16	0.03

Specification Data	
Material	PVC
Note	Designed for 1 5/8" strut channel, end caps are desired when the end of the channel need to be enclosed. The cap easily installs by pressing it onto the end of the channel opening

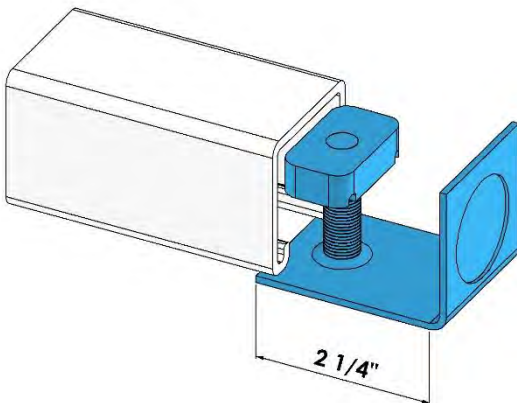
SAFETY END CAP METAL



Part #	L (in.)	Approx. Wt (lbs.)
A-655 1 5/8	1 5/8	0.07
A-655 1	1	0.04
A-655 13/16	13/16	0.03

Specification Data	
Material	Carbon Steel
Note	Designed for 1 5/8" strut channel, end caps are desired when the end of the channel need to be enclosed

END CAP WITH KNOCK-OUT



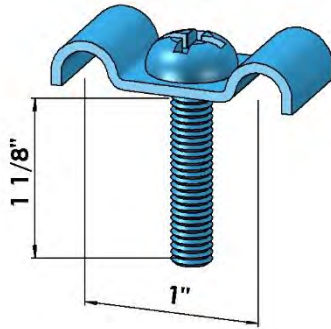
Part #	Conduit Size (in.)	Channel Size (in.)
A-2511 1/2	1/2	1 5/8
A-2511 3/4	3/4	1 5/8

Specification Data	
Material	Carbon Steel
Approx. Wt. (lbs.)	0.27
Strut Nut Thickness (in.)	1/4
Note	Supplied with 1/4" x 5/8" Flat Head Machine Screws and 1/4" Strut Nut No Spring

These specifications are for reference only. Aimco International Group Corp. reserves the right to make changes to the design without prior notice.

FIXTURE STUD NUT

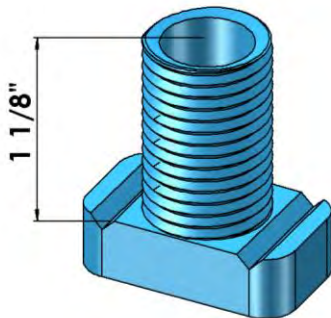
Part # | A-2636



Specification Data	
Bolt Size (in.)	1/4"-20 x 1 1/4"
Approx. Wt. (lbs.)	0.04

WIRING STUD NUT

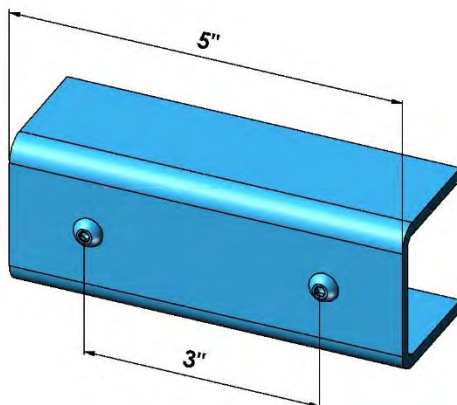
Part # | A-2625



Specification Data	
Material	Aluminum
NPT Size (in.)	1/2
Approx. Wt. (lbs.)	0.08

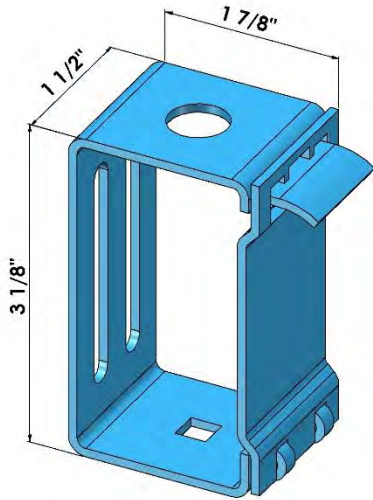
INSIDE SPLICE

Part # | A-643



Specification Data	
Channel Size (in.)	1 5/8
Thickness (in.)	1/8
Approx. Wt. (lbs.)	0.61
Note	Supplied with two Hex Socket Head Jamb Screws.

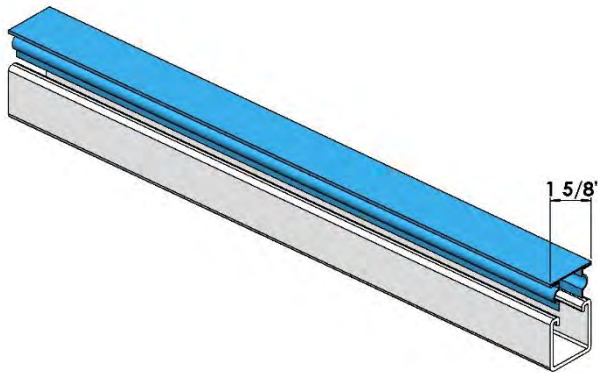
These specifications are for reference only. Aimco International Group Corp. reserves the right to make changes to the design without prior notice.



CHANNEL HANGER

Part # | A-2632

Specification Data	
Top Hole Dia. (in.)	9/16
Bottom Square (in.)	9/32
Design Load (lbs.)	120
Safety Factor	3
Approx. Wt. (lbs.)	0.24
Note	Round Washers are required on the top and bottom side of the thread rod connection. After the channel with closure strip is in place, the space between the closure strip and the top of the hanger allow removal of the closure strip for addition or removal of wire.



PLASTIC CLOSURE STRIP

Part # | A-707PL 10

Specification Data	
Material	High impact polystyrene plastic
Length (ft.)	10
Approx. Wt. (lbs.)	1.22
Note	A closure strip is required on the channel to create a wire raceway. Designed to snap into the continuous slot of all 1 5/8" wide strut channel. Including steel, stainless steel, aluminum and fiberglass. Due to the design of the self-retaining feature, closure strip can be removed by prying with a tool, such as a screwdriver.

These specifications are for reference only. Aimco International Group Corp. reserves the right to make changes to the design without prior notice.

Section 9: Strut Channels

FUNCTIONS AND FEATURES

Strut support system provide an economical solution for electrical, mechanical and industrial supports. Strut channels are ideal for individual fastening or for efficiently constructing pipe routes, they provide adjustment for wall mounting, constructing trapeze supports and other suspension and heavy applications. Typical strut support system applications include: cable management supports, pipe and conduits supports, HVAC and duct supports, strut racking systems, ceiling grids, machine guarding, panel stands and etc.

In the strut support system, there are an extensive range of strut channels varying in sizes, gauges, and multiple combinations. Channels are manufactured by a series of forming dies, or rolls, which progressively cold-work the strip steel into the desired channel configuration. This method produces a cross section of uniform dimensions within a tolerance of plus or minus 0.015" on outside dimensions.

STANDARD LENGTHS

Channels are manufactured in 10 feet and 20 feet lengths with a tolerance of plus or minus 1/8". Other lengths are available upon request.

LOAD DATA

All beam and column load data pertains to carbon steel and stainless steel channels. Load tables and charts are constructed to be in accordance with [Specification For The Design of Cold-Formed Steel Structural Members 2007 Edition], published by the American Iron and Steel Institute (AISI) using ASD Method.

MATERIALS

Pre-Galvanized Steel (ASTM A653)

Carbon Steel (ASTM A1011)

Stainless Steel - Type 304 or 316 (ASTM A240)

Aluminum Alloy - Type 6063-T5 (ASTM B221)

FINISHES

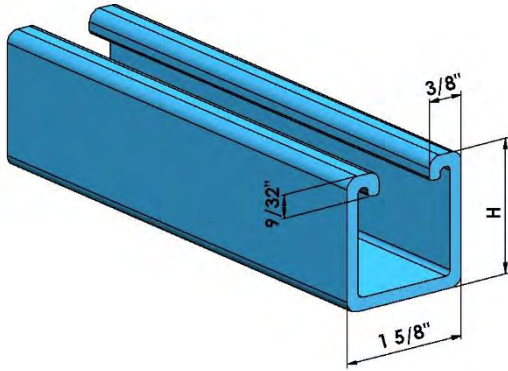
Pre-Galvanized Steel (ASTM A653)

Stainless Steel - Type 304 or 316 (ASTM A240)

Hot-Dip Galvanized (ASTM A123)

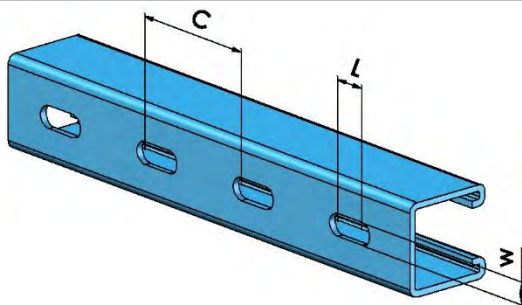
Epoxy Coating (ASTM B117)

These specifications are for reference only. Aimco International Group Corp. reserves the right to make changes to the design without prior notice.



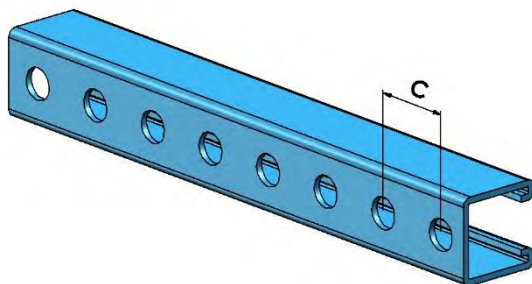
SINGLE CHANNEL (SOLID)

Part #	Material	H (in.)	Thickness	Stainless Steel Type	Alloy
A-90	Steel	3 1/4	12Ga	-	-
A-10	Steel	2 7/16	12Ga	-	-
A-20	Steel	1 5/8	12Ga	-	-
A-40	Steel	1 5/8	14Ga	-	-
A-30	Steel	1 5/8	16Ga	-	-
A-80	Steel	1 3/8	12Ga	-	-
A-50	Steel	1	12Ga	-	-
A-70	Steel	13/16	14Ga	-	-
A-60	Steel	13/16	16Ga	-	-
A-20SS4	Stainless Steel	1 5/8	0.09"	304	-
A-20SS6	Stainless Steel	1 5/8	0.09"	316	-
A-50SS4	Stainless Steel	1	0.09"	304	-
A-50SS6	Stainless Steel	1	0.09"	316	-
A-10AL	Aluminum	2 7/16	0.08"	-	6063-T5
A-20AL	Aluminum	1 5/8	0.08"	-	6063-T5
A-60AL	Aluminum	13/16	0.07"	-	6063-T5



SINGLE CHANNEL (SLOTS)

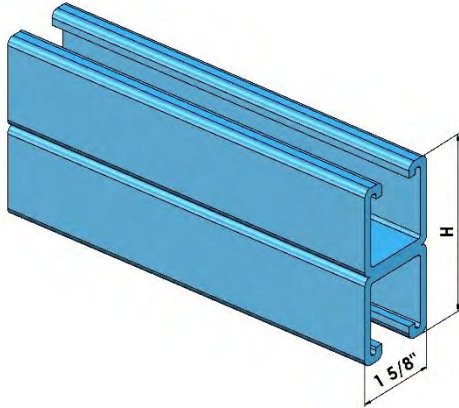
Part #	Size (in.)	Slot Size W (in.)	Slot Size L (in.)	Centers C (in.)
A-20SL	1 5/8	9/16	1 1/8	2
A-50SL	1	9/16	1 1/8	2
A-70SL	13/16	9/16	1 1/8	2



SINGLE CHANNEL (HOLES)

Part #	Hole Dia. (in.)	Centers C (in.)
A-20HS	9/16	1 1/2

These specifications are for reference only. Aimco International Group Corp. reserves the right to make changes to the design without prior notice.



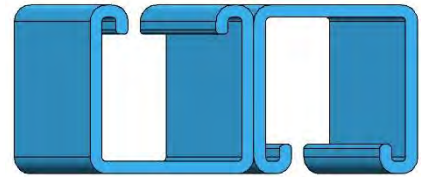
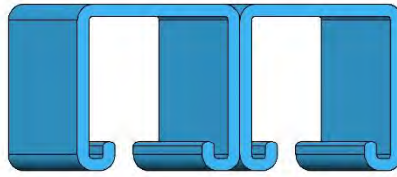
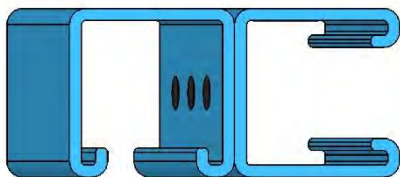
**DOUBLE CHANNEL
BACK-TO-BACK**

Part #	Material	H (in.)	Thickness	Stainless Steel Type	Alloy
A-90BB	Steel	6 1/2	12Ga	-	-
A-10BB	Steel	4 7/8	12Ga	-	-
A-20BB	Steel	3 1/4	12Ga	-	-
A-40BB	Steel	3 1/4	14Ga	-	-
A-30BB	Steel	3 1/4	16Ga	-	-
A-80BB	Steel	2 3/4	12Ga	-	-
A-50BB	Steel	2	12Ga	-	-
A-70BB	Steel	1 5/8	14Ga	-	-
A-60BB	Steel	1 5/8	16Ga	-	-
A-20BBSS4	Stainless Steel	3 1/4	0.09"	304	-
A-20BBSS6	Stainless Steel	3 1/4	0.09"	316	-
A-50BBSS4	Stainless Steel	2	0.09"	304	-
A-50BBSS6	Stainless Steel	2	0.09"	316	-
A-20BBAL	Aluminum	3 1/4	0.08"	-	6063-T5

BACK-TO-SIDE

SIDE-TO-SIDE

ONE-UP-ONE-DOWN



These specifications are for reference only. Aimco International Group Corp. reserves the right to make changes to the design without prior notice.

Section 10: Adjustable Hinges & Braces

FUNCTIONS AND FEATURES

Adjustable Hinges and Braces are part of the metal framing system, and can be used as part of an engineered seismic restraint system. They are ideal for attaching sway bracing to Mechanical, Electrical, and Plumbing (MEP) system supports, they also attach to strut channels, trapezes and structures. To prevent loosening, the hinges rotate on 1/2" bolts using nylon nuts.

MATERIALS

Carbon Steel (ASTM A1011)

FINISHES

Zinc Electro-Galvanized (ASTM B633)

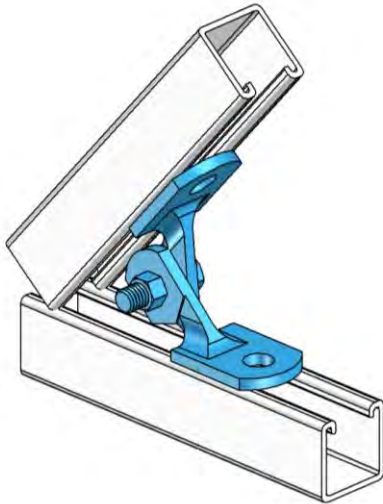
Hot-Dip Galvanized (ASTM A123/A153)

STAINLESS STEEL OPTIONS

Some of the Adjustable Hinges & Braces are available in 304 Stainless Steel or 316 Stainless Steel (ASTM A240)

NOTE

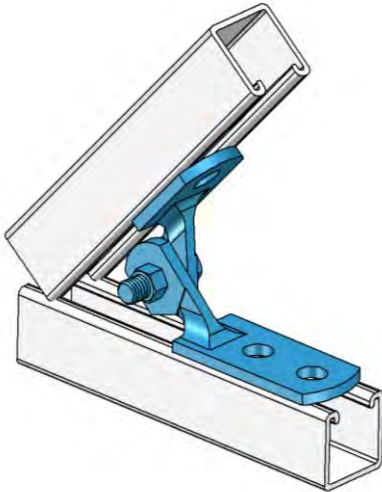
Loads are limited by the Pull-Out strength and Resistance to Slip strength of the Spring Nuts.



ADJUSTABLE HINGE TWO HOLE

Part # | A-292A

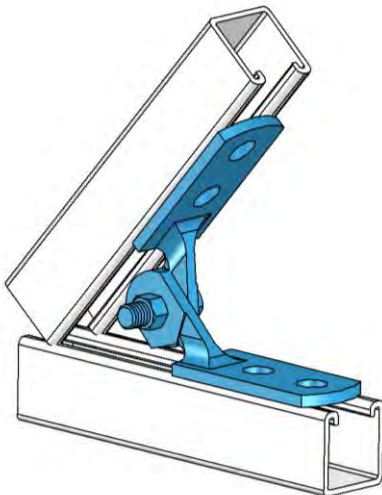
Specification Data	
Hole Dia. (in.)	9/16
Hole Spacing from End (in.)	13/16
Hole Spacing on Center (in.)	1 5/8
Width (in.)	1 5/8
Thickness (in.)	1/4
Bolt & Nut Included (in.)	1/2
Approx. Wt. (lbs.)	0.92



ADJUSTABLE HINGE THREE HOLE

Part # | A-293A

Specification Data	
Hole Dia. (in.)	9/16
Hole Spacing from End (in.)	13/16
Hole Spacing on Center (in.)	1 5/8
Width (in.)	1 5/8
Thickness (in.)	1/4
Bolt & Nut Included (in.)	1/2
Approx. Wt. (lbs.)	1.06

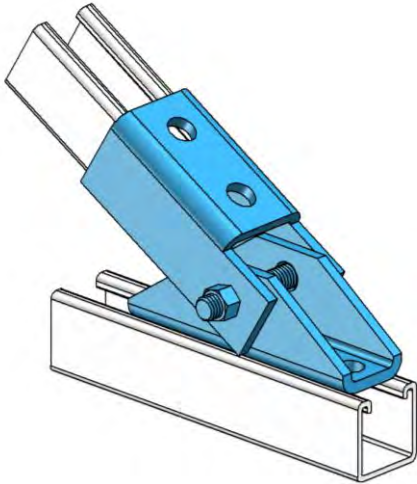


ADJUSTABLE HINGE FOUR HOLE

Part # | A-294A

Specification Data	
Hole Dia. (in.)	9/16
Hole Spacing from End (in.)	13/16
Hole Spacing on Center (in.)	1 5/8
Width (in.)	1 5/8
Thickness (in.)	1/4
Bolt & Nut Included (in.)	1/2
Approx. Wt. (lbs.)	1.20

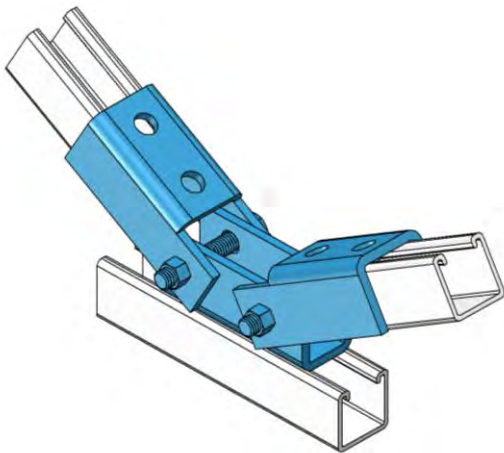
These specifications are for reference only. Aimco International Group Corp. reserves the right to make changes to the design without prior notice.



ADJUSTABLE BRACE

Part # | A-298A

Specification Data	
Hole Dia. (in.)	9/16
Hole Spacing from End (in.)	13/16
Hole Spacing on Center (in.)	1 7/8
Width (in.)	1 5/8
Thickness (in.)	1/4
Bolt & Nut Included (in.)	1/2
Approx. Wt. (lbs.)	3.06



ADJUSTABLE BRACE DOUBLE

Part # | A-299A

Specification Data	
Hole Dia. (in.)	9/16
Hole Spacing from End (in.)	13/16
Hole Spacing on Center (in.)	1 7/8
Width (in.)	1 5/8
Thickness (in.)	1/4
Bolt & Nut Included (in.)	1/2
Approx. Wt. (lbs.)	5.18

These specifications are for reference only. Aimco International Group Corp. reserves the right to make changes to the design without prior notice.

Section 11: Pipe Rollers & Accessories

FUNCTIONS AND FEATURES

Pipe Rollers & Accessories are designed to mount on strut channels in the metal framing system, they are mainly used for the support of pipe with longitudinal movement. Pipe Rollers and Supports are designed to fit into the standard openings of 1 5/8" strut channels to support runs of piping where desired, and to secure the pipe in place. When pipe line is insulated, total outside diameter of pipe and covering should be used to determine size of hanger.

MATERIALS

Carbon Steel (ASTM A1011)

Malleable Cast Iron

FINISHES

Hot-Dip Galvanized (ASTM A123/A153)

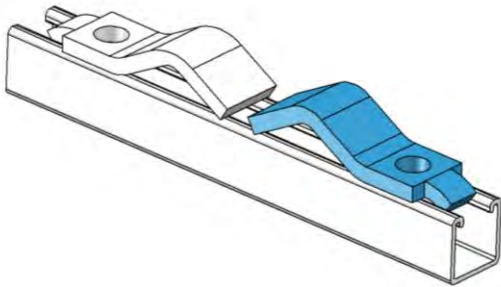
Zinc Electro-Galvanized (ASTM B633)

STAINLESS STEEL OPTIONS

Some of the Adjustable Hinges & Braces are available in 304 Stainless Steel or 316 Stainless Steel (ASTM A240)

PIPE BLOCK

Part # | A-11PC

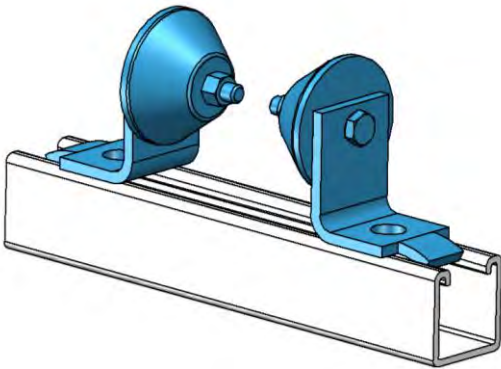


Specification Data

Approx. Wt. (lbs.)	
Note	For pipe diameters 2" – 8"

PIPE ROLLER

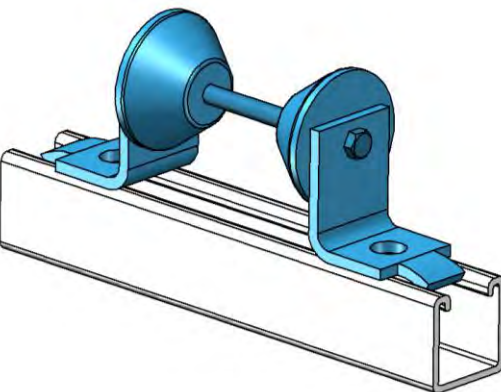
Part # | A-1PR



Specification Data

Design load (lbs.)	500
Approx. Wt. (lbs.)	2.56
Note	For pipe diameters 1/2" – 4"

PIPE ROLLER CONNECTED



Part #	Pipe Dia. (in.)	Approx. Wt. (lbs.)
A-2PR	1 – 3	5.15
A-3PR	1 – 4	5.18
A-4PR	1 – 6	5.26
A-5PR	1 – 8	5.28

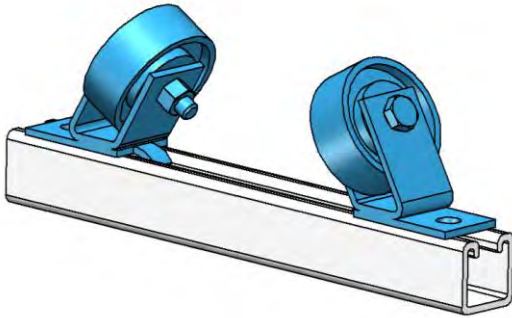
Specification Data

Design load (lbs.)	750
Note	For pipe diameters 1" – 8"

These specifications are for reference only. Aimco International Group Corp. reserves the right to make changes to the design without prior notice.

PIPE ROLLER DOUBLE

Part # | A-6PR

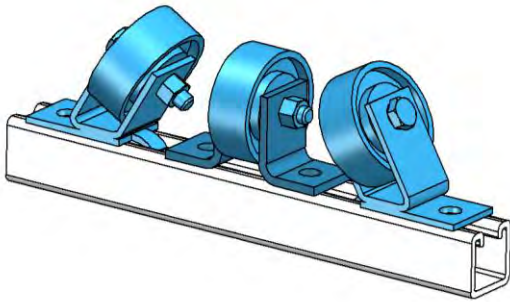


Specification Data

Design load (lbs.)	1500
Approx. Wt. (lbs.)	5.58
Note	For pipe diameters 6" – 16"

PIPE ROLLER TRIPLE

Part # | A-7PR



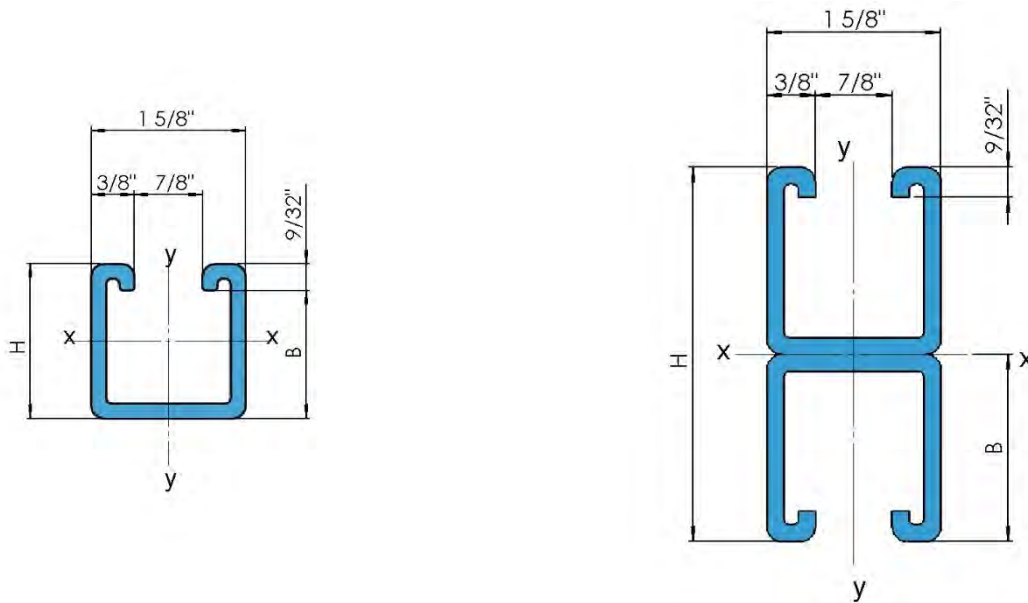
Specification Data

Design load (lbs.)	2000
Approx. Wt. (lbs.)	8.89
Note	For pipe diameters 16" – 24"

These specifications are for reference only. Aimco International Group Corp. reserves the right to make changes to the design without prior notice.

Technical Data

Elements of Steel Strut Channels



A = Area of Section I = Moment of Inertia S = Section of Modulus r = Radius of Gyration

Size	Ga.	H	A (in ²)	Section X – X			B (in.)	Section Y – Y		
				I (in ⁴)	S (in ³)	r (in.)		I (in ⁴)	S (in ³)	r (in.)
2 7/16	12	2.438	0.728	0.512	0.389	0.849	1.110	0.332	0.414	0.684
1 5/8	12	1.625	0.558	0.186	0.206	0.580	0.714	0.232	0.290	0.652
1 5/8	16	1.625	0.339	0.123	0.139	0.604	0.742	0.141	0.177	0.664
1 5/8	14	1.625	0.409	0.141	0.156	0.599	0.729	0.173	0.215	0.661
1	12	1.000	0.428	0.056	0.096	0.355	0.424	0.168	0.210	0.621
13/16	16	0.813	0.234	0.020	0.043	0.308	0.345	0.088	0.109	0.611
13/16	14	0.813	0.294	0.026	0.057	0.298	0.342	0.109	0.133	0.609
1 3/8	12	1.375	0.499	0.121	0.153	0.488	0.591	0.204	0.250	0.637
3 1/4	12	3.250	0.899	1.110	0.639	1.107	1.509	0.435	0.535	0.696
4 7/8	12	4.875	1.456	2.860	1.170	1.394	2.438	0.665	0.825	0.680
3 1/4	12	3.250	1.116	0.954	0.587	0.921	1.625	0.475	0.583	0.655
3 1/4	16	3.250	0.678	0.613	0.377	0.951	1.625	0.248	0.285	0.666
3 1/4	14	3.250	0.818	0.738	0.454	0.942	1.625	0.326	0.390	0.662
2	12	2.000	0.856	0.262	0.262	0.554	1.000	0.325	0.392	0.617
1 5/8	16	1.625	0.468	0.097	0.122	0.460	0.813	0.175	0.216	0.613
1 5/8	14	1.625	0.588	0.121	0.159	0.455	0.813	0.217	0.265	0.609
2 3/4	12	2.750	0.998	0.590	0.429	0.770	1.375	0.407	0.500	0.640
6 1/2	12	6.500	1.798	6.275	1.928	1.868	3.250	0.869	1.070	0.696

All dimensions are in inches unless otherwise noted.

Beam Load Data (Simple Beam Uniform Load)

Size	Ga.	12" Beam				14" Beam			
		Net Allowable Uniform Load		Net Uniform Load at Deflection		Net Allowable Uniform Load		Net Uniform Load at Deflection	
		(lbs.)	DEFL	Span/180 (lbs.)	Span/240 (lbs.)	(lbs.)	DEFL	Span/180 (lbs.)	Span/240 (lbs.)
3 1/4	12	10,625	0.01	10,625	10,625	7,080	0.02	7,080	7,080
2 7/16	12	6,635	0.01	6,635	6,635	4,425	0.02	4,425	4,425
1 5/8	12	3,445	0.02	3,445	3,445	2,295	0.03	2,295	2,295
1 5/8	14	2,745	0.02	2,745	2,745	1,830	0.03	1,830	1,830
1 3/8	12	2,625	0.02	2,625	2,625	1,750	0.04	1,750	1,750
1 5/8	16	2,315	0.02	2,315	2,315	1,540	0.03	1,540	1,540
1	12	1,550	0.02	1,550	1,550	1,030	0.05	1,030	1,030
13/16	14	925	0.03	925	925	615	0.06	615	615
13/16	16	805	0.03	805	805	535	0.06	535	535

Size	Ga.	24" Beam				30" Beam			
		Net Allowable Uniform Load		Net Uniform Load at Deflection		Net Allowable Uniform Load		Net Uniform Load at Deflection	
		(lbs.)	DEFL	Span/180 (lbs.)	Span/240 (lbs.)	(lbs.)	DEFL	Span/180 (lbs.)	Span/240 (lbs.)
6 1/2	12	5,305	0.01	5,305	5,305	5,150	0.01	5,150	5,150
3 1/4	12	5,305	0.03	5,305	5,305	4,245	0.05	4,245	4,245
4 7/8	12	3,910	0.01	3,910	3,910	3,910	0.02	3,910	3,910
2 7/16	12	3,315	0.04	3,315	3,315	2,650	0.06	2,650	2,650
3 1/4	12	2,625	0.02	2,625	2,625	2,625	0.03	2,625	2,625
2 3/4	12	2,225	0.02	2,225	2,225	2,225	0.05	2,225	2,225
3 1/4	14	1,755	0.02	1,755	1,755	1,755	0.03	1,755	1,755
1 5/8	12	1,720	0.06	1,720	1,720	1,375	0.09	1,375	1,375
2	12	1,595	0.04	1,595	1,595	1,595	0.07	1,595	1,595
1 5/8	14	1,370	0.06	1,370	1,370	1,095	0.09	1,095	1,095
1 3/8	12	1,310	0.07	1,310	1,310	1,045	0.10	1,045	1,045
3 1/4	16	1,215	0.01	1,215	1,215	1,215	0.02	1,215	1,215
1 5/8	16	1,155	0.06	1,155	1,155	925	0.09	925	925
1 5/8	14	885	0.05	885	885	885	0.09	885	885
1	12	775	0.09	775	775	620	0.14	620	560
1 5/8	16	600	0.04	600	600	600	0.07	600	600
13/16	14	460	0.11	460	425	370	0.17	360	270
13/16	16	400	0.11	400	370	320	0.17	315	235

All dimensions are in inches unless otherwise noted.

Size	Ga.	36" Beam				42" Beam			
		Net Allowable Uniform Load		Net Uniform Load at Deflection		Net Allowable Uniform Load		Net Uniform Load at Deflection	
		(lbs.)	DEFL	Span/180 (lbs.)	Span/240 (lbs.)	(lbs.)	DEFL	Span/180 (lbs.)	Span/240 (lbs.)
6 1/2	12	5,150	0.02	5,150	5,150	5,150	0.03	5,150	5,150
4 7/8	12	3,910	0.03	3,910	3,910	3,910	0.05	3,910	3,910
3 1/4	12	3,535	0.07	3,535	3,535	3,025	0.09	3,025	3,025
3 1/4	12	2,625	0.06	2,625	2,625	2,625	0.09	2,625	2,625
2 3/4	12	2,225	0.08	2,225	2,225	2,095	0.11	2,095	2,095
2 7/16	12	2,205	0.09	2,205	2,205	1,890	0.12	1,890	1,890
3 1/4	14	1,755	0.05	1,755	1,755	1,755	0.08	1,755	1,755
2	12	1,435	0.11	1,435	1,435	1,230	0.16	1,230	1,230
3 1/4	16	1,215	0.04	1,215	1,215	1,215	0.07	1,215	1,215
1 5/8	12	1,145	0.13	1,145	1,145	980	0.17	980	980
1 5/8	14	910	0.13	910	910	780	0.17	780	780
1 3/8	12	870	0.15	870	870	745	0.20	745	650
1 5/8	14	820	0.14	820	820	700	0.19	700	640
1 5/8	16	770	0.13	770	770	660	0.18	660	660
1 5/8	16	600	0.12	600	600	595	0.19	595	545
1	12	515	0.20	515	385	440	0.27	380	280
13/16	14	305	0.24	250	185	260	0.33	180	135
13/16	16	265	0.25	215	160	225	0.33	155	115

Size	Ga.	48" Beam				54" Beam			
		Net Allowable Uniform Load		Net Uniform Load at Deflection		Net Allowable Uniform Load		Net Uniform Load at Deflection	
		(lbs.)	DEFL	Span/180 (lbs.)	Span/240 (lbs.)	(lbs.)	DEFL	Span/180 (lbs.)	Span/240 (lbs.)
6 1/2	12	5,150	0.04	5,150	5,150	5,150	0.06	5,150	5,150
4 7/8	12	3,910	0.07	3,910	3,910	3,910	0.10	3,910	3,910
3 1/4	12	2,645	0.12	2,645	2,645	2,435	0.15	2,435	2,435
3 1/4	12	2,425	0.13	2,425	2,425	2,150	0.16	2,150	2,150
3 1/4	14	1,755	0.12	1,755	1,755	1,665	0.16	1,665	1,665
2 3/4	12	1,830	0.15	1,830	1,830	1,620	0.19	1,620	1,620
2 7/16	12	1,650	0.15	1,650	1,650	1,465	0.19	1,465	1,465
3 1/4	16	1,215	0.10	1,215	1,215	1,215	0.14	1,215	1,215
2	12	1,070	0.20	1,070	1,055	950	0.26	950	830
1 5/8	12	855	0.22	855	760	755	0.28	755	595
1 5/8	14	680	0.23	680	600	605	0.29	605	470
1 3/8	12	650	0.26	650	495	575	0.33	520	385
1 5/8	14	615	0.25	615	485	545	0.32	515	380
1 5/8	16	575	0.23	575	500	510	0.29	510	395
1 5/8	16	520	0.25	520	415	460	0.32	435	325
1	12	380	0.35	285	215	340	0.45	225	165
13/16	14	225	0.43	140	100	200	0.55	105	80
13/16	16	200	0.44	120	90	175	0.55	95	70

All dimensions are in inches unless otherwise noted.

TECHNICAL DATA

Size	Ga.	60" Beam				72" Beam			
		Net Allowable Uniform Load		Net Uniform Load at Deflection		Net Allowable Uniform Load		Net Uniform Load at Deflection	
		(lbs.)	DEFL	Span/180 (lbs.)	Span/240 (lbs.)	(lbs.)	DEFL	Span/180 (lbs.)	Span/240 (lbs.)
6 1/2	12	5,150	0.08	5,150	5,150	5,150	0.13	5,150	5,150
4 7/8	12	3,885	0.13	3,885	3,885	3,225	0.19	3,225	3,225
3 1/4	12	2,110	0.18	2,110	2,110	1,750	0.26	1,750	1,750
3 1/4	12	1,935	0.20	1,935	1,935	1,605	0.28	1,605	1,605
3 1/4	14	1,495	0.20	1,495	1,495	1,240	0.28	1,240	1,240
2 3/4	12	1,455	0.23	1,455	1,455	1,205	0.33	1,205	1,085
2 7/16	12	1,315	0.24	1,315	1,315	1,090	0.35	1,090	945
3 1/4	16	1,215	0.19	1,215	1,215	1,035	0.28	1,035	1,035
2	12	855	0.32	855	665	705	0.46	615	455
1 5/8	12	680	0.35	645	480	565	0.51	445	330
1 5/8	14	540	0.36	510	380	450	0.51	350	260
1 3/8	12	515	0.41	420	310	425	0.59	285	210
1 5/8	14	485	0.39	410	305	400	0.56	280	205
1 5/8	16	455	0.36	725	320	380	0.51	290	215
1 5/8	16	415	0.39	350	260	340	0.56	240	175
1	12	300	0.55	180	135	250	0.79	120	90
13/16	14	180	0.67	85	60	150	0.97	55	40
13/16	16	155	0.68	75	55	130	0.98	50	35

Size	Ga.	84" Beam				96" Beam			
		Net Allowable Uniform Load		Net Uniform Load at Deflection		Net Allowable Uniform Load		Net Uniform Load at Deflection	
		(lbs.)	DEFL	Span/180 (lbs.)	Span/240 (lbs.)	(lbs.)	DEFL	Span/180 (lbs.)	Span/240 (lbs.)
6 1/2	12	4,585	0.19	4,585	4,585	4,000	0.25	4,000	4,000
4 7/8	12	2,755	0.26	2,755	2,755	2,400	0.33	2,400	2,400
3 1/4	12	1,495	0.36	1,495	1,460	1,300	0.47	1,300	1,110
3 1/4	12	1,365	0.38	1,365	1,245	1,190	0.51	1,190	945
3 1/4	14	1,060	0.38	1,060	965	920	0.50	920	730
2 3/4	12	1,025	0.45	1,025	790	890	0.59	800	595
2 7/16	12	930	0.47	925	690	810	0.61	700	520
3 1/4	16	880	0.38	880	805	765	0.50	765	610
2	12	600	0.62	440	325	520	0.81	330	240
1 5/8	12	480	0.69	320	235	415	0.90	240	175
1 5/8	14	380	0.70	250	185	330	0.91	190	140
1 3/8	12	360	0.80	205	150	315	1.05	150	110
1 5/8	14	340	0.77	200	145	295	1.00	150	105
1 5/8	16	320	0.70	210	155	280	0.91	160	115
1 5/8	16	290	0.77	170	125	250	1.00	125	90
1	12	210	1.08	85	60	180	1.41	60	40
13/16	14	125	1.32	40	25	110	1.73	25	20
13/16	16	110	1.33	35	25	95	1.74	25	15

All dimensions are in inches unless otherwise noted.

Size	Ga.	108" Beam				120" Beam			
		Net Allowable Uniform Load		Net Uniform Load at Deflection		Net Allowable Uniform Load		Net Uniform Load at Deflection	
		(lbs.)	DEFL	Span/180 (lbs.)	Span/240 (lbs.)	(lbs.)	DEFL	Span/180 (lbs.)	Span/240 (lbs.)
6 1/2	12	3,545	0.32	3,545	3,545	3,175	0.39	3,175	3,175
4 7/8	12	2,125	0.42	2,125	2,125	1,905	0.52	1,905	1,820
3 1/4	12	1,150	0.59	1,150	870	1,030	0.73	935	695
3 1/4	12	1,050	0.64	990	735	935	0.78	790	585
3 1/4	14	815	0.63	770	570	725	0.78	615	455
2 3/4	12	785	0.75	625	460	700	0.92	495	360
2 7/16	12	715	0.78	545	405	640	0.96	435	320
3 1/4	16	675	0.63	640	475	605	0.78	510	375
2	12	455	1.03	250	180	405	1.27	195	140
1 5/8	12	365	1.14	185	135	325	1.40	145	100
1 5/8	14	290	1.15	145	105	260	1.42	115	80
1 3/8	12	275	1.33	115	80	245	1.64	90	60
1 5/8	14	255	1.27	110	80	225	1.57	85	60
1 5/8	16	245	1.16	120	90	220	1.43	95	70
1 5/8	16	220	1.27	95	65	195	1.57	70	50
1	12	160	1.78	45	30	140	2.20	30	20
13/16	14	95	2.19	20	10	80	2.70	10	5
13/16	16	80	2.20	15	10	70	2.72	10	5

Size	Ga.	144" Beam				168" Beam			
		Net Allowable Uniform Load		Net Uniform Load at Deflection		Net Allowable Uniform Load		Net Uniform Load at Deflection	
		(lbs.)	DEFL	Span/180 (lbs.)	Span/240 (lbs.)	(lbs.)	DEFL	Span/180 (lbs.)	Span/240 (lbs.)
6 1/2	12	2,625	0.56	2,625	2,625	2,225	0.77	2,225	2,025
4 7/8	12	1,565	0.75	1,565	1,240	1,325	1.02	1,205	885
3 1/4	12	850	1.05	535	465	715	1.43	450	325
3 1/4	12	765	1.13	530	385	640	1.53	370	265
3 1/4	14	595	1.13	410	300	500	1.53	285	205
2 3/4	12	570	1.33	325	235	475	1.81	220	150
2 7/16	12	520	1.38	290	210	440	1.88	200	140
3 1/4	16	495	1.13	345	250	415	1.53	240	170
2	12	325	1.83	120	80	270	2.49	70	45
1 5/8	12	265	2.02	90	60	220	2.75	55	35
1 5/8	14	210	2.04	70	50	175	2.78	45	30
1 3/8	12	200	2.36	50	35	160	3.21	30	15
1 5/8	14	180	2.25	50	30	150	3.07	25	10
1 5/8	16	180	2.06	60	40	150	2.80	40	25
1 5/8	16	155	2.25	40	25	125	3.07	20	10
1	12	110	3.17	15	5	90	4.31	-	-
13/16	14	65	3.89	-	-	50	5.30	-	-
13/16	16	55	3.92	-	-	45	5.33	-	-

All dimensions are in inches unless otherwise noted.

Size	Ga.	192" Beam				216" Beam			
		Net Allowable Uniform Load		Net Uniform Load at Deflection		Net Allowable Uniform Load		Net Uniform Load at Deflection	
		(lbs.)	DEFL	Span/180 (lbs.)	Span/240 (lbs.)	(lbs.)	DEFL	Span/180 (lbs.)	Span/240 (lbs.)
6 1/2	12	1,925	1.00	1,925	1,515	1,685	1.27	1,590	1,165
4 7/8	12	1,140	1.34	895	650	995	1.69	680	485
3 1/4	12	615	1.87	330	235	535	2.37	240	165
3 1/4	12	550	2.00	260	180	470	2.54	185	120
3 1/4	14	425	2.00	205	140	370	2.54	145	95
2 3/4	12	405	2.37	150	100	345	3.00	100	60
2 7/16	12	375	2.45	140	95	325	3.11	95	60
3 1/4	16	355	2.00	170	120	305	2.54	120	80
2	12	220	3.25	40	15	185	4.12	15	-
1 5/8	12	185	3.59	30	15	155	4.54	15	-
1 5/8	14	150	3.63	25	15	125	4.60	15	5
1 3/8	12	135	4.19	10	-	115	5.31	-	-
1 5/8	14	120	4.01	10	-	100	5.07	-	-
1 5/8	16	125	3.65	20	10	105	4.62	10	-
1 5/8	16	105	4.01	5	-	85	5.07	-	-
1	12	70	5.63	-	-	60	7.13	-	-
13/16	14	40	6.92	-	-	30	8.76	-	-
13/16	16	35	6.97	-	-	30	8.82	-	-

Size	Ga.	240" Beam			
		Net Allowable Uniform Load		Net Uniform Load at Deflection	
		(lbs.)	DEFL	Span/180 (lbs.)	Span/240 (lbs.)
6 1/2	12	1,495	1.57	1,255	910
4 7/8	12	875	2.09	525	365
3 1/4	12	470	2.92	180	115
3 1/4	12	410	3.13	130	75
3 1/4	14	320	3.13	100	60
2 3/4	12	295	3.70	60	30
2 7/16	12	280	3.84	655	35
3 1/4	16	265	3.13	85	50
2	12	155	5.09	-	-
1 5/8	12	135	5.61	-	-
1 5/8	14	110	5.68	-	-
1 3/8	12	95	6.55	-	-
1 5/8	14	80	6.26	-	-
1 5/8	16	90	5.71	-	-
1 5/8	16	70	6.26	-	-
1	12	50	8.80	-	-
13/16	14	25	10.81	-	-
13/16	16	20	10.89	-	-

Note:

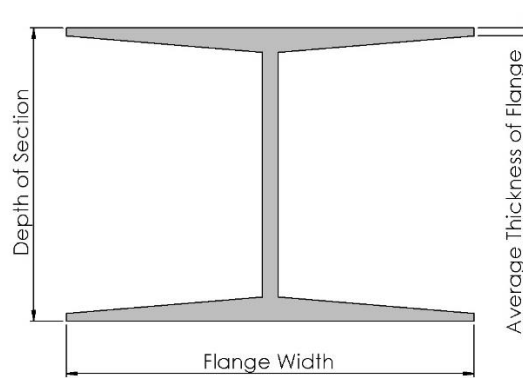
The beam loads shown above are for Steel and Stainless Steel Strut Channels based on 25,000 PSI allowable stress about the x-axis as pictured on page I. Safety Factor 1.67 to Yield Strength.

The beam loads shown are the net allowable uniformly distributed load, which is defined as the maximum allowable uniformly distributed load less the weight of the beam and therefore is the additional weight which the beam can carry. For concentrated loads at the center of the span, multiply load by 0.50 and deflection by 0.80. For Slotted and Knock-out Channels, multiply load by 0.85.

Simple long span beams must be supported to prevent rotation and be adequately braced so as to prevent twisting. If this is not the case, the allowable loads will be reduced.

All dimensions are in inches unless otherwise noted.

I Beam Data



Nominal Size	Depth of Section	Flange Width	Average Thickness of Flange	Wt. per Ft. (lbs.)
3	3	2.330	0.170	5.70
		2.509	0.349	7.50
4	4	2.663	0.193	7.70
		2.796	0.326	9.50
5	5	3.004	0.214	10.00
		3.284	0.494	14.75
6	6	3.332	0.232	12.50
		3.565	0.465	17.25
7	7	3.662	0.252	15.30
		3.860	0.450	20.00
8	8	4.001	0.271	18.40
		4.171	0.441	23.00
10	10	4.661	0.311	25.40
		4.944	0.594	35.00
12	12	5.000	0.350	31.80
		5.078	0.428	35.00
		5.252	0.462	40.80
		5.477	0.687	50.00
15	15	5.501	0.411	42.90
		5.640	0.550	50.00
18	18	6.001	0.461	54.70
		6.251	0.711	70.00
20	20	6.255	0.505	66.00
		6.385	0.635	75.00
		7.060	0.660	86.00
		7.200	0.800	96.00
24	24	7.000	0.500	80.00
		7.245	0.745	100.00
		7.870	0.620	106.00
		8.050	0.800	121.00

All dimensions are in inches unless otherwise noted.

Electrical Metallic Tubing (EMT) Data

Nominal Conduit Size	O.D.	I.D.	Wall Thickness	Weight Per 10 Ft. (lbs.)	Weight of Conduit and Conductors Per 10 Ft. (lbs.)
3/8	0.577	0.493	0.042	2.30	3.66
1/2	0.706	0.622	0.042	2.85	5.06
3/4	0.922	0.824	0.049	4.35	8.43
1	1.163	1.049	0.057	6.40	13.03
1 1/4	1.510	1.380	0.065	9.50	21.23
1 1/2	1.740	1.610	0.065	11.00	26.98
2	2.197	2.067	0.065	14.00	40.18
2 1/2	2.875	2.731	0.072	20.50	57.90
3	3.500	3.356	0.072	25.00	82.63
3 1/2	4.000	3.834	0.083	32.50	109.80
4	4.500	4.334	0.083	37.00	136.40

Steel Rigid Conduit Data

Nominal Conduit Size	O.D.	I.D.	Wall Thickness	Weight Per 10 Ft. (lbs.)	Weight of Conduit and Conductors Per 10 Ft. (lbs.)
3/8	0.675	0.493	0.104	5.15	6.51
1/2	0.840	0.632	0.104	7.90	10.11
3/4	1.050	0.836	0.107	10.50	14.58
1	1.315	1.063	0.126	15.30	21.93
1 1/4	1.660	1.394	0.133	20.10	31.83
1 1/2	1.900	1.624	0.138	24.90	40.88
2	2.375	2.083	0.146	33.20	59.38
2 1/2	2.875	2.489	0.193	52.70	90.10
3	3.500	3.090	0.250	68.26	125.90
3 1/2	4.000	3.570	0.215	83.10	160.40
4	4.500	4.050	0.225	97.23	196.70
5	5.563	5.073	0.245	131.36	287.60
6	6.625	6.093	0.266	174.53	400.30

All dimensions are in inches unless otherwise noted.

Aluminum Rigid Conduit Data

Nominal Conduit Size	O.D.	I.D.	Wall Thickness	Weight with Couplings Attached Per 10 Ft. (lbs.)	Weight of Conduit and Conductors Per 10 Ft. (lbs.)
1/2	0.840	0.632	0.104	2.74	4.95
3/4	1.050	0.836	0.107	3.64	7.72
1	1.315	1.063	0.126	5.30	11.93
1 1/4	1.660	1.394	0.133	6.96	18.69
1 1/2	1.900	1.624	0.138	8.22	24.20
2	2.375	2.083	0.146	11.57	37.75
2 1/2	2.875	2.489	0.193	18.25	55.65
3	3.500	3.090	0.250	23.89	81.52
3 1/2	4.000	3.570	0.215	28.77	106.10
4	4.500	4.050	0.225	24.00	133.40
5	5.563	5.073	0.245	46.54	202.80
6	6.625	6.093	0.266	61.25	287.00

Intermediate Metal Conduit (IMC) Data

Nominal Conduit Size	O.D.	I.D.	Wall Thickness	Weight with Couplings Attached Per 10 Ft. (lbs.)	Weight of Conduit and Conductors Per 10 Ft. (lbs.)
1/2	0.815	0.675	0.070	6.00	8.21
3/4	1.029	0.879	0.075	8.20	12.28
1	1.290	1.120	0.085	11.60	18.23
1 1/4	1.638	1.468	0.085	15.00	26.73
1 1/2	1.883	1.703	0.090	18.20	34.18
2	2.360	2.170	0.095	24.20	50.38
2 1/2	2.857	2.597	0.130	42.80	77.50
3	3.476	3.216	0.130	52.60	106.90
3 1/2	3.971	3.711	0.130	61.20	134.60
4	4.466	4.206	0.130	68.20	163.20

National Electrical Code Data

Conduit Size	Max. Support Span (ft.)
1/2 to 3/4	10
1	12
1 1/4 to 1 1/2	14
2 to 2 1/2	16
3 to 6	20

All dimensions are in inches unless otherwise noted.

Schedule 40 Steel Pipe Data

Nominal Pipe Size	Pipe O.D.	Wall Thickness	Weight of Pipe (lbs./ft.)	Weight of Pipe Filled with Water (lbs./ft.)	Maximum Span (ft.)	Recommended Hanger Rod Sizes
3/8	0.675	0.091	0.6	0.7	7'	3/8-16
1/2	0.840	0.109	0.8	0.9	7'	3/8-16
3/4	1.050	0.113	1.1	1.3	7'	3/8-16
1	1.315	0.133	1.7	2.1	7'	3/8-16
1 1/4	1.660	0.140	2.3	2.9	7'	3/8-16
1 1/2	1.900	0.145	2.7	3.6	9'	3/8-16
2	2.375	0.154	3.6	5.0	10'	3/8-16
2 1/2	2.875	0.203	5.8	7.9	11'	1/2-13
3	3.500	0.216	7.6	10.8	12'	1/2-13
3 1/2	4.000	0.226	9.1	13.4	13'	1/2-13
4	4.500	0.237	10.8	16.3	14'	5/8-11
5	5.563	0.258	14.6	23.2	16'	5/8-11
6	6.625	0.280	19.0	31.5	17'	3/4-10
8	8.625	0.322	28.5	50.1	19'	3/4-10
10	10.75	0.365	40.5	74.6	22'	7/8-9
12	12.75	0.406	51.1	102.1	23'	7/8-9
14	14.000	0.437	63.0	121.5	25'	1-8
16	16.000	0.500	83.0	159.5	27'	1-8
18	18.000	0.563	105.0	202.2	28'	1-8
20	20.000	0.539	123.0	243.4	30'	1 1/4-7
24	24.000	0.687	171.0	345.2	32'	1 1/4-7

All dimensions are in inches unless otherwise noted.

Schedule 80 Steel Pipe Data

Nominal Pipe Size	Pipe O.D.	Wall Thickness	Weight of Pipe (lbs./ft.)	Weight of Pipe Filled with Water (lbs./ft.)	Maximum Span (ft.)	Recommended Hanger Rod Sizes
3/8	0.675	0.126	0.7	0.8	7'	3/8-16
1/2	0.840	0.147	1.1	1.2	7'	3/8-16
3/4	1.050	0.154	1.5	1.7	7'	3/8-16
1	1.315	0.179	2.2	2.5	7'	3/8-16
1 1/4	1.660	0.191	3.0	3.5	7'	3/8-16
1 1/2	1.900	2.000	3.6	4.3	9'	3/8-16
2	2.375	0.218	5.0	6.3	10'	3/8-16
2 1/2	2.875	0.276	7.6	9.4	11'	1/2-13
3	3.500	0.300	10.2	13.0	12'	1/2-13
3 1/2	4.000	0.318	12.5	16.3	13'	1/2-13
4	4.500	0.337	15.0	20.0	14'	5/8-11
5	5.563	0.375	20.8	28.7	16'	5/8-11
6	6.625	0.432	28.6	39.9	17'	3/4-10
8	8.625	0.500	43.4	63.1	19'	3/4-10
10	10.750	0.593	64.4	95.5	22'	7/8-9
12	12.750	0.687	88.6	132.6	23'	7/8-9
14	14.000	0.750	107.0	158.2	25'	1-8
16	16.000	0.843	137.0	206.7	27'	1-8
18	18.000	0.937	171.0	259.5	28'	1-8
20	20.000	1.031	209.0	318.4	30'	1 1/4-7
24	24.000	1.218	297.0	455.2	32'	1 1/4-7

All dimensions are in inches unless otherwise noted.

AWWA Ductile Iron Pipe Data

Nominal Pipe Size	Class	O.D. of Ductile Iron Pipe	Wall Thickness	Weight of Pipe (lbs./ft.)	Weight of Pipe Filled with Water (lbs./ft.)
3	53	3.96	0.31	11.2	15.0
4	53	4.80	0.32	14.2	20.1
6	53	6.90	0.34	22.0	35.1
8	53	9.05	0.36	31.0	54.0
10	53	11.10	0.38	40.4	76.8
12	53	13.20	0.40	50.7	103.0
14	53	15.30	0.42	62.4	133.5
16	53	17.40	0.43	72.8	165.9
18	53	19.50	0.44	83.6	201.5
20	53	21.60	0.45	95.2	241.0
24	53	25.80	0.47	119.2	329.4
30	53	32.00	0.51	161.3	487.8
36	53	38.30	0.58	219.5	688.8
42	53	44.50	0.65	285.2	920.1
48	53	50.80	0.72	360.3	1189.2
54	53	57.10	0.81	455.0	1502.2

No-Hub Cast Iron Soil Pipe Data

Nominal Pipe Size	Cast Iron O.D. Size	Wall Thickness	Weight of Pipe (lbs./ft.)	Weight of Pipe Filled with Water (lbs./ft.)
1 1/2	1.90	0.16	2.70	3.55
2	2.35	0.16	3.60	5.00
3	3.35	0.16	5.20	8.32
4	4.38	0.19	7.40	12.84
5	5.30	0.19	9.60	17.84
6	6.30	0.19	11.00	22.92
8	8.38	0.23	18.00	39.34
10	10.50	0.28	26.20	59.82
12	12.50	0.28	35.50	84.01

All dimensions are in inches unless otherwise noted.

Copper Tubing (Type L) Data

Nominal Tubing Size	O.D. Size	Wall Thickness	Weight of Tubing (lbs./ft.)	Weight of Tubing Filled with Water (lbs./ft.)
1/4	0.375	0.030	0.12	0.15
3/8	0.500	0.035	0.20	0.26
1/2	0.625	0.040	0.28	0.38
5/8	0.750	0.042	0.36	0.51
3/4	0.875	0.045	0.45	0.66
1	1.125	0.050	0.65	1.01
1 1/4	1.375	0.055	0.88	1.42
1 1/2	1.625	0.060	1.14	1.91
2	2.125	0.070	1.75	3.09
2 1/2	2.625	0.080	2.48	4.54
3	3.125	0.090	3.33	6.28
3 1/2	3.625	0.100	4.29	8.28
4	4.125	0.110	5.38	10.57
5	5.125	0.125	7.61	15.69
6	6.125	0.140	10.20	21.81
8	8.125	0.200	19.29	39.49

Copper Tubing (Type K) Data

Nominal Tubing Size	O.D. Size	Wall Thickness	Weight of Tubing (lbs./ft.)	Weight of Tubing Filled with Water (lbs./ft.)
1/4	0.375	0.035	0.14	0.17
3/8	0.500	0.049	0.27	0.32
1/2	0.625	0.049	0.34	0.43
5/8	0.750	0.049	0.42	0.56
3/4	0.875	0.065	0.64	0.83
1	1.125	0.065	0.84	1.18
1 1/4	1.375	0.065	1.04	1.57
1 1/2	1.625	0.072	1.36	2.10
2	2.125	0.083	2.06	3.37
2 1/2	2.625	0.095	2.92	4.92
3	3.125	0.109	4.00	6.92
3 1/2	3.625	0.120	5.12	9.02
4	4.125	0.134	6.51	11.57
5	5.125	0.160	9.67	17.67
6	6.125	0.192	13.87	25.07
8	8.125	0.271	25.90	45.40

All dimensions are in inches unless otherwise noted.

Recommended Hanger Spacing and Rod Size for Copper Tubing

Nominal Tubing Size	Maximum Span (ft.)	Recommended Hanger Rod Size
1/2	5'	3/8-16
3/4	5'	3/8-16
1	6'	3/8-16
1 1/4	7'	3/8-16
1 1/2	8'	3/8-16
2	8'	3/8-16
2 1/2	9'	1/2-13
3	10'	1/2-13
3 1/2	11'	1/2-13
4	12'	1/2-13
5	13'	1/2-13
6	14'	5/8-11
8	16'	3/4-10

Regular Schedule Glass Pipe Data

Nominal Pipe Size	O.D. Size	Wall Thickness	Weight of Pipe (lbs./ft.)	Weight of Pipe Filled with Water (lbs./ft.)
1 1/2	1.84	0.12	0.6	1.5
2	2.34	0.14	0.9	2.3
3	3.41	0.17	1.6	4.8
4	4.53	0.20	2.6	8.4
6	6.66	0.24	4.7	17.5

Heavy Schedule Glass Pipe Data

Nominal Pipe Size	O.D. Size	Wall Thickness	Weight of Pipe (lbs./ft.)	Weight of Pipe Filled with Water (lbs./ft.)
1	1.31	0.16	0.6	0.9
1 1/2	1.84	0.17	0.8	1.5
2	2.34	0.17	1.1	2.4
3	3.41	0.20	2.0	5.0
4	4.53	0.26	3.4	8.8
6	6.66	0.33	6.3	18.7

All dimensions are in inches unless otherwise noted.

Schedule 40 PVC Plastic Pipe Data

Nominal Pipe Size	Pipe O.D.	Wall Thickness	Weight of Pipe (lbs./ft.)	Weight of Pipe Filled with Water (lbs./ft.)
1/8	0.405	0.068	0.04	0.06
1/4	0.540	0.088	0.07	0.11
3/8	0.675	0.091	0.10	0.18
1/2	0.840	0.109	0.15	0.25
3/4	1.050	0.113	0.20	0.40
1	1.315	0.133	0.30	0.70
1 1/4	1.660	0.140	0.40	1.00
1 1/2	1.900	0.145	0.50	1.40
2	2.375	0.154	0.60	2.00
2 1/2	2.875	0.203	1.00	3.10
3	3.500	0.216	1.30	4.50
3 1/2	4.000	0.226	1.60	5.90
4	4.500	0.237	1.90	7.40
5	5.563	0.258	2.80	11.40
6	6.625	0.280	3.30	15.40
8	8.625	0.322	5.30	26.90
10	10.75	0.366	7.50	41.60
12	12.75	0.406	10.00	58.50

Schedule 80 PVC Plastic Pipe Data

Nominal Pipe Size	Pipe O.D.	Wall Thickness	Weight of Pipe (lbs./ft.)	Weight of Pipe Filled with Water (lbs./ft.)
1/8	0.405	0.095	0.05	0.06
1/4	0.540	0.119	0.09	0.12
3/8	0.675	0.126	0.10	0.16
1/2	0.840	0.147	0.10	0.20
3/4	1.050	0.154	0.20	0.40
1	1.315	0.179	0.40	0.70
1 1/4	1.660	0.191	0.50	1.00
1 1/2	1.900	0.200	0.60	1.30
2	2.375	0.218	0.90	2.20
2 1/2	2.875	0.276	1.30	3.10
3	3.500	0.300	1.80	4.60
3 1/2	4.000	0.318	2.20	6.00
4	4.500	0.337	2.60	7.60
5	5.563	0.375	4.10	12.00
6	6.625	0.432	5.00	16.30
8	8.625	0.500	8.00	27.80
10	10.75	0.593	11.90	43.20
12	12.75	0.687	16.30	60.30

All dimensions are in inches unless otherwise noted.

Spacing of Hangers for Schedule 40 PVC Plastic Pipe Data

Temperature	Support Spacing in Feet for Pipe Size of						
	1/2 to 3/4	1 to 1 1/4	1 1/2 to 2	2 1/2	3	4	6
-7°C (20°F)	5.00	5.50	5.80	6.66	6.80	7.33	7.80
4°C (40°F)	4.75	5.25	5.50	6.33	6.50	7.00	7.50
16°C (60°F)	4.50	5.00	5.25	6.00	6.25	6.50	7.00
27°C (80°F)	4.25	4.66	5.00	5.50	5.80	6.25	6.80
38°C (100°F)	4.00	4.33	4.66	5.25	5.50	5.80	6.33
43°C (110°F)	3.75	4.00	4.33	4.80	5.25	5.50	5.80
49°C (120°F)	3.33	3.75	3.80	4.50	4.75	5.00	5.33
54°C (130°F)	3.00	3.33	3.50	4.00	4.25	4.50	4.80
60°C (140°F)	2.66	2.80	3.00	3.50	3.66	3.80	4.25
66°C (150°F)	2.00	2.25	2.50	2.80	3.00	3.25	3.50

Spacing of Hangers for Schedule 80 PVC Plastic Pipe Data

Temperature	Support Spacing in Feet for Pipe Size of							
	1/2 to 3/4	1	1 1/4 to 1 1/2	2	2 1/2	3	4	6
-7°C (20°F)	5.75	6.33	6.66	7.00	7.80	8.20	8.66	9.80
4°C (40°F)	5.50	6.00	6.33	6.50	7.50	7.75	8.25	9.33
16°C (60°F)	5.25	5.75	6.00	6.25	7.00	7.33	7.80	8.80
27°C (80°F)	4.80	5.33	5.66	6.00	6.66	7.00	7.33	8.33
38°C (100°F)	4.50	5.00	5.25	5.50	6.33	6.50	6.80	7.80
43°C (110°F)	4.33	4.60	4.80	5.12	5.80	6.00	6.33	7.33
49°C (120°F)	3.80	4.33	4.50	4.75	5.33	5.50	5.80	6.50
54°C (130°F)	3.50	3.80	4.00	4.33	4.75	5.00	5.25	6.00
60°C (140°F)	3.00	3.33	3.50	3.66	4.25	4.33	4.66	5.12
66°C (150°F)	2.50	2.75	3.00	3.12	3.33	3.50	3.75	4.25

All dimensions are in inches unless otherwise noted.

Rod Size as Determined by Steel Pipe Size for Fire Protection

Steel Pipe Size	Maximum Span (ft.)	Rod Size
1 to 1 1/4	12'	3/8-16
1 1/2 to 4	15'	3/8-16
5 to 8	15'	1/2-13
10 to 12	15'	5/8-11

Rod Size as Determined by Copper Tubing Size for Fire Protection

Copper Tubing Size	Maximum Span (ft.)	Rod Size
3/4 to 1	8'	3/8-16
1 1/4 to 1 1/2	15'	3/8-16
2 to 3	15'	3/8-16
3 1/4 to 4	15'	3/8-16
5 to 8	15'	1/2-13

Hanger Rod Load Capacities – Hot-Rolled Steel Rod

Rod Dia.	Max. Rated Load (lbs.)	Root Area	Weight per Foot (lbs.)	Nominal Pipe Size
3/8	610	0.068	0.376	1/2 to 2
1/2	1130	0.126	0.668	2 1/2 to 3
5/8	1810	0.202	1.040	4 to 5
3/4	2710	0.302	1.500	6 to 8
7/8	4960	0.552	2.670	10 to 18
1 1/8	8000	0.889	4.170	20 to 24

All dimensions are in inches unless otherwise noted.

Conversion Factors for Units of Measurement

Imperial to Metric

Convert From	To	Multiply By
Length		
Inch	Millimeter	25.4000
Foot	Meter	0.3048
Yard	Meter	0.9144
Mile	Kilometer	1.6093
Area		
Square Inch	Square Millimeter	645.1600
Square Foot	Square Meter	0.0929
Square Yard	Square Meter	0.8361
Square Mile	Square Kilometer	2.5900
Acre	Square Meter	4046.8730
Acre	Hectare	0.4047
Volume		
Cubic Inch	Cubic Millimeter	16387.0600
Cubic Foot	Cubic Meter	0.0283
Cubic Yard	Cubic Meter	0.7646
Gallon	Liter	3.7854
Quart	Liter	0.9463
Mass		
Ounce	Gram	28.350
Pound	Kilogram	0.4540
Short Ton	Kilogram	907.1850
Force		
Ounce-Force	Newton	0.2780
Pound-Force	Newton	4.4482
Bending Moment		
Pound-Force-Inch	Newton-Meter	0.1130
Pound-Force-Foot	Newton-Meter	1.3558
Pressure, Stress		
Pound-Force per Square Inch	Kilopascal	6.8948
Foot of Water (39.2 F)	Kilopascal	2.9890
Inch of Mercury (32 F)	Kilopascal	3.3864
Energy, Work, Heat		
Foot-Pound-Force	Joule	1.3558
British Thermal Unit	Joule	1055.0560
Calorie	Joule	4.1870
Kilowatt Hour	Joule	3,600,000
Power		
Foot-Pound-Force/Second	Watt	1.3558
British Thermal Unit/Hour	Watt	0.2931
Horsepower	Kilowatt	0.7457
Angle		
Degree	Radian	0.0175
Temperature		
Degree Fahrenheit	Degree Celsius	$(F^{\circ}-32)/1.8$

Metric to Imperial

Convert From	To	Multiply By
Length		
Millimeter	Inch	0.0394
Meter	Foot	3.2808
Meter	Yard	1.0936
Kilometer	Mile	0.6214
Area		
Square Millimeter	Square Inch	0.0016
Square Meter	Square Foot	10.7639
Square Meter	Square Yard	1.1960
Square Kilometer	Square Mile	0.3861
Square Meter	Acre	0.0002
Hectare	Acre	2.4710
Volume		
Cubic Millimeter	Cubic Inch	0.000061
Cubic Meter	Cubic Foot	35.3147
Cubic Meter	Cubic Yard	1.3080
Liter	Gallon	0.2642
Liter	Quart	1.0567
Mass		
Gram	Ounce	0.0353
Kilogram	Pound	2.2046
Kilogram	Short Ton	0.0011
Force		
Newton	Ounce-Force	3.5970
Newton	Pound-Force	0.2248
Bending Moment		
Newton-Meter	Pound-Force-Inch	8.8507
Newton-Meter	Pound-Force-Foot	0.7376
Pressure, Stress		
Kilopascal	Pound-Force per Square Inch	0.1450
Kilopascal	Foot of Water (39.2 F)	0.3346
Kilopascal	Inch of Mercury (32 F)	0.2953
Energy, Work, Heat		
Joule	Foot-Pound-Force	0.7376
Joule	British Thermal Unit	0.0009
Joule	Calorie	0.2389
Joule	Kilowatt Hour	2.7800
Power		
Watt	Foot-Pound-Force/Second	0.7376
Watt	British Thermal Unit/Hour	3.4121
Kilowatt	Horsepower	1.3410
Angle		
Radian	Degree	57.2958
Temperature		
Degree Celsius	Degree Fahrenheit	$1.8 \times C^{\circ} + 32$

All dimensions are in inches unless otherwise noted.



AIMCO[★]

INTERNATIONAL GROUP

60 North Wind Place, Toronto, ON, Canada, M1S 5L4
(416)-431-6565 1-(855)-701-5995
www.AimcoInternational.com